

the **leader** 

APRIL 1996

VOLUME 26, NO. 8

Scout Out Spring!

PHOTO CONTEST WINNERS



From the Commissioner's Tent

by Herb Pitts

It's Spring! With birds, buds and maple syrup aplenty the notion of completing another Scouting year is crowding related thoughts and events into the forefront of my mind.

We're planning more Scoutrees activities as a continuation of last year's big 50 millionth tree planting. This great environmental and conservation project is one of our Movement's best community efforts. Benefits flow to local and world neighbours. It deserves our continued support; I hope your group will seek the local recognition it deserves. Our efforts to expand the Scoutree program seems destined to keep growing — just as it should. We've got a good thing growing; let's keep it that way!

This spring, let's look a little further into our future than normally. When next September starts another Scouting cycle, we'll be heading into our 90th Anniversary Year — 1997. We'll have a lot to celebrate. It's not

too soon to start planning how your region or group might want to mark the occasion.

Win-Win Opportunities

The 90th Anniversary should present a great opportunity for Scouts in all localities to help focus attention on themselves and on the Movement. We provide an excellent youth program matched only by the Girl Guides. Perhaps we can enhance our image by showing and talking about our accomplishments, past and present. Try to promote both what you've done and what you intend to do. This could provide many win-win opportunities for Scouting and your community.

Talking about "win-win" opportunities, did you know that CJ'97 is only 15 months away? Jamboree planning is well advanced. The CJ'97 program and venue will provide all who attend a unique Scouting experience. Planned activities are both exciting and challenging. Being there as a participant during the 90th Anniversary will give you a place in Canadian Scouting history. Registration has begun on a "first come, first served" basis. BE THERE — BE PART OF IT!

Youth Matters

As I write these words, our National Youth Committee is preparing to hold its second meeting as a standing committee of National Council. Its agenda is filling up and busy time is predicted as they start to affect the direction of Canadian Scouting. I'm looking forward to a strong youth voice at all levels. That voice has to be broadly representative of our younger members, therefore, communication (and intercommunication) will be crucial. Watch **the Leader** for more youth updates.

Speaking of youth matters reminds me that three of our younger members will attend the World Youth Forum and the World Scout Conference in Norway in July. Canada's members will be fine examples. We have much to learn about how other countries' youth affect their national programs. Our representatives will have an excellent opportunity to share their experiences.

Before signing off, I'm reminded of a phrase that keeps popping into my mind. What we're all about is "*better Scouting for more youth.*" Let's watch for excellent opportunities in the year ahead to accomplish this goal.

See you on the trail. ^λ



Herb Pitts
National Commissioner

Visit Our Web Page

The **Leader** magazine is on Scouts Canada's web site. You can visit our web page at Scouting's on-line address: <http://www.scouts.ca>.

At present we're just setting up our **Leader** magazine web

page, so you'll find only a few items. Naturally this will increase in the future. Tell us about what you'd like to see when visiting the site. Read more about it on p.39 of this issue.

Executive Editor
Garth Johnson

Editor
Allen Macartney

Art Director
Richard Petsche

Advertising
Laureen Duquette

Circulation
Pam Phaneuf



The Canadian Leader Magazine

is published 10 times a year by
Canyouth Publications Ltd.

PO Box 5112,
Stn LCD-Merivale,
Ottawa ON K2C 3H4
Phone: (613) 224-5131.
Fax: (613) 224-3571.
E-mail: leader@scouts.ca

Yearly subscription:
registered members
Scouts Canada \$7
non-members \$10
outside Canada \$18

The Leader serves as a program resource for Scouters and other adults who work with young people.

John Rietveld,
Executive Director,
Communications and Revenue
Development Service, Scouts Canada

Editorial contributions are made on a voluntary basis.
Unsolicited submissions welcome.

Advertising Policy: Advertisement of a product or service does not indicate endorsement by publishers.

Publishers do not assume any responsibility by warranty or otherwise with respect to products advertised.

The Leader is printed on paper containing 50% recycled fibre.

Publications mail registration #2405.

ISSN 0711-5377

Cover photo: Neil MacIntosh,
First prize photo contest winner

the leader

The Canadian Leader Magazine

April 1996

Volume 26, No.8

FEATURES

Scouting Is... Photo Contest Winners	4
Great, Gregarious Grandparents	7
The Worldwide Web of Life	8
CJ'97: See You at the VSP	11
Child Abuse How to protect Scouting youth: Part 2	12
Wow! What a Successful Recruitment Campaign	14
Tunnel Vision Discover a world down under	16
Book Talk	23
38th Jamboree on the Air	24
A Chance to Celebrate Youth	38
Scouts Canada's World Wide Web Site	39

REGULARS

Swap Shop Cub cartoons	18
Fun at the Pond Responsible stewards.....	20
Network Scouting for the whole family.....	22
Paksak A well dressed pack totem	25
Sharing When Beavers lose their cool	26
Outdoors It's a wonderful life	29
Patrol Corner Paperweight pots	30
Venturer Log Service + vocation = challenge.....	32
For Volunteers Double the Beavers, Double the fun.....	34

ALSO

Editorial Page	2	Supply News	33
National News	19	Scouter's 5 & Songs ...	35
Cross-Country Photos ...	28		



Photo winners make a splash!

page 4

Scouting Is...

Photo Contest Winners

The *Leader* magazine and Supply Services proudly announce the winners of our fourth-ever photography contest. Scouting members across the country sent us almost 300 images celebrating their youth activities.

This enthusiastic response was no doubt sparked by Supply Service's many great prizes. They include a three-person Premier North Trail Clip Stalker III tent, a spacious Cherokee Point backpack, a cosy Scout System 1 sleeping bag, 10 Scout Apprentice Swiss Army knives, 20 Scouts Canada fanny packs and up to 50 Scouts Canada baseball caps.

"What great pictures," our judges agreed when faced with a huge table blanketed by colourful photos. "It won't be easy choosing the best ones." Eric Harris (managing editor of *Canadian Geographic* magazine), John Rietveld (executive director of Scouts Canada's Communications and



Second prize winner

Lauren McKinnon took this outstanding picture of Venturer Chris Gallant taking a short break in Pukaskwa National Park. Scouting is sometimes a restful moment.

Third prize winner

Tony Horvatin caught some youthful expressions of delight. While out for a walk and picnic, these Beavers discovered irrefutable evidence that it doesn't matter how little you are: Patience and determination can conquer almost any problem.

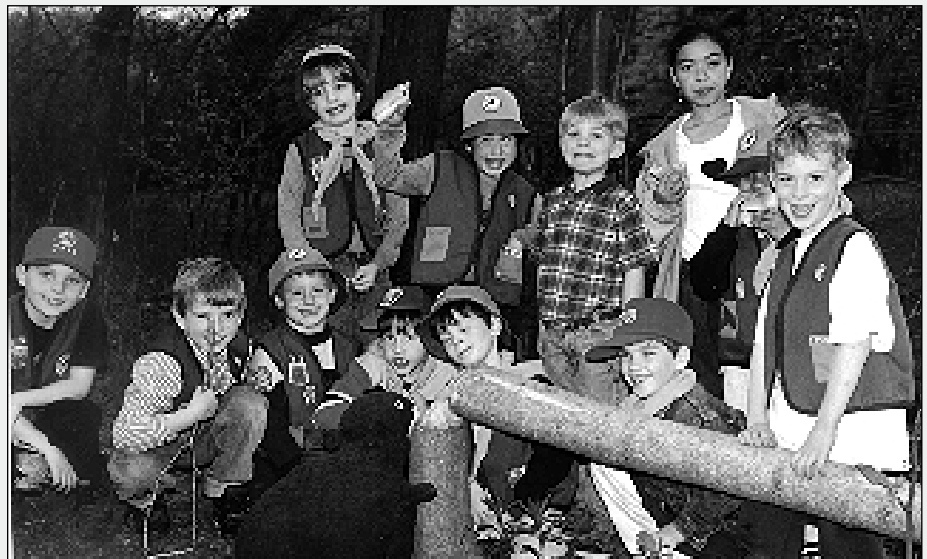

Revenue Development Service) and Richard Petsche (**Leader** art director), identified the winners after hours of discussion and scrutiny.

Personal Definitions

Our *Scouting Is...* photo contest inspired more than just great pictures. It drove Brent Dicks of St. Laurent, PQ, to wax poetic and extol the virtues of Scouting. He wrote,

Scouting is a shining young face.
Scouting is a warm friendly place.
Scouting is a walk in the park.
Scouting is a hike after dark.

Scouting is a place to have fun.
Scouting is a day in the sun.
Scouting is a campfire's warm glow.
Scouting is the good friends I know.

What does Scouting mean to you?

For Roger Smith of Dalhousie, NB, Scouting is a pie in the face! Cecil Keeping says it's an unforgettable scuba diving weekend in British Columbia. For Mary MacLaurin's Cornwall Beavers, ON, it means gathering around a campfire for a wiener roast. It's building kites, tying knots and playing a tune on homemade flutes, according to Charlie McPhee of New Waterford, NS. For Trudy Heath's Scouts, St. Anthony, NF, it's pelting the other side's fort with great gobs of wonderful mud.

Others wrote that Scouting is sharing the pain of a bee sting with your pack, fine dining at camp, putting on dry socks during a bike hike, building a rope bridge at a father and son camp, learning to build a fire and wondering if it will light.

Winner's Circle

Neil MacIntosh of Baie Comeau, PQ, won first prize this year for his incredibly well-framed shot of a group of Cubs on a wilderness hike. (See it on our front cover.) From their surprised expressions, the Cubs weren't expecting to find anything unusual in the dark tunnel. Neil's new tent will make future overnight hiking trips even more enjoyable.

Lauren McKinnon, a Venturer advisor from Thunder Bay, ON, will have almost enough room for a kitchen sink in her second place prize — a backpack. This summer's camping and canoe trips just won't be the same. She captured on film one of her Venturers relaxing beside a foaming river during a long hike in Pukaskwa National Park.



"All aboard for adventure!"

Ron Schmiedge of Regina, SK, found these Scout pirates just as they set off on their homemade raft.



Target practising hosers

David Villeneuve of Orleans, ON, successfully evaded the water gushing from this fire hose as his Cubs took their best shot at a suspended target. Though everyone wore raincoats, some Cubs still managed to get wet. Surprised?



Scouting is a safe adventure

Gary Siegle of Winnipeg, MB, saw the potential in this winter skiing scene. These would-be Inuit hunters wore cardboard snow goggles to protect their eyes from the bright sun.



On a four day canoe trip, Jim Robson of Saskatoon, SK, put down his paddle long enough to show that "where there's a *wind*, there's a way."

Tony Horvatin will be warm this summer when camping with his third prize Scout System sleeping bag. His winning photo captured the excited faces of the 32nd Toronto Colony when they discovered a tree recently gnawed and felled by a real beaver. What made the find more interesting was the realization that this beaver cut the tree down in an urban Toronto park.

In addition to these top three winners, we have awarded ten knives, twenty fanny packs and almost 50 baseball caps to other deserving photogra-

phers. Some of their pictures are displayed on these pages. All winners will be notified soon and sent their prizes.

The Leader will keep all photos (including non-winning pictures) for use in other Scouting publications, except those accompanied by a self-addressed, stamped envelope. Of course, photographers will receive full credit if their images appear in the magazine.

Focus, Aim, Shoot

Keep on sending **the Leader** your best Scouting photographs. The mag-

azine needs many images each month to illustrate feature articles and columns. We might publish one of your best shots on a future cover, in the Cross-Country Photo section, in a calendar, on posters or even in Scouts Canada's annual report.

Thank you to everyone who contributed a photo or inspiring words. You helped make this the most successful **Leader** magazine photography contest ever! ^



Finger-lickin' good

Moments after clicking the shutter, Steven Cramm of Deer Lake, NF, dug into these cupcakes with his Cubs.



Stan Williams of Calgary, AB, took this picture of wide eyes and nervous smiles. Why would anyone be afraid of handling a giant scorpion?



Margaret Keith of Farmington, BC, balanced on a slippery, snow-covered rope bridge trying to keep Scout Trevor Smith focused in her camera.



"I hear it!" Tina Ercolino of Markham, ON, watched as her 2nd Milliken Mills Cubs had a great time visiting a local television station.

Great, Gregarious Grandparents

by Jane Walker

For the past two years our Mother's Day Tea had proven very successful as a late spring event, but last year we decided that Beavers might enjoy an evening with a different twist. Someone suggested that we could celebrate grandparents. A Grandparents' Night? Great idea.

Our Ailsa Craig colony comes from a small, rural area in Ontario. Most Beavers had grandparents nearby who would be delighted to attend the party. We encouraged those few who couldn't invite their grandparents to ask "someone special."

Suggestions flooded in once we formed an initial plan. (Don't forget to ask your Beavers for their thoughts.) A meeting notice went home in our monthly calendar. Beavers could invite as many grandparents as they wished. We asked parents to reply to one of our leaders several weeks before the event. That allowed us to follow-up any who hadn't called; we wanted to make sure each child had someone important coming.

Before our grandparent evening, we helped the Beavers make personal invitations for their guests. Pop-out cards are easy to create. Start by folding a paper in half lengthwise. Draw a number of straight, parallel lines (5 cm) on the paper starting at the folded side; cut with scissors. (See diagram) Open the card like a tent and push the strips through. Take some red construction paper, fold it in half and cut out small hearts. Glue them after matching their fold lines to the strip fold lines. Now glue this pop-up card inside another card, taking care not to glue any of the pop-up strips to the outer card. Now simply draw an appropriate picture on the front of the card and words on the inside. (*Holiday Pop-Up Cards*, Kids Can Press, is a great party resource.)

Hugs and Cookies

A week before our big event each Beaver made a wooden cutout of the

word "HUGS" for a gift. (The night before a leader had cut the words out of 2 cm thick pine with his scroll saw.) The children lovingly sanded them and, with a short brown cord, attached a verse which read: "I'm giving you this hug for the times I can't be there, just to let you know how much I care. So when you're all alone, close your eyes and think of me and give yourself a great big squeeze."



A grandparent's evening would be great for either Beavers or Cubs.

Photo: Louis Looi

While one group worked on their wooden hugs, another was kept busy in the kitchen making party cookies. The groups rotated through so everyone could help with all preparations.

"Welcome Grandpa!"

On the big night, leaders arrived early to set up our meeting place. Pret-

ty flowers, surrounded by the wooden "hugs," were centred on tea tables. When the first visitors arrived, our Beavers were waiting eagerly. Two welcoming youth greeted people at the door.

After our opening, each child introduced his special visitors. Then we sang some of our colony's favourite songs; the words caused many smiles. When we crooned "Down by the Bay", two of the grandparents made up impromptu riddles for the songs. What a hit! When this happened, we knew our party was rolling along well. Next came a comical rendition of "Singing in the Rain" (complete with all the silly actions). Naturally we insisted that our guests join us. All around the room people giggled and guffawed.

We didn't need an ice-breaker game, but we played one anyway. Everyone received a different sized nut or bolt and went from person to person, looking for its mate. Beavers then split into lodges and, working with their guests, made a picture frame. We used cardboard and recycled jigsaw puzzle pieces to frame a loving verse about grandparents.

Soon it was time to eat. After our closing, twenty happy Beavers rode home with equally happy grandparents. What a delightful way to draw grandparents into the Scouting family. ^

— Jane Walker works with the 1st Ailsa Craig Beaver Colony, ON.

Card construction

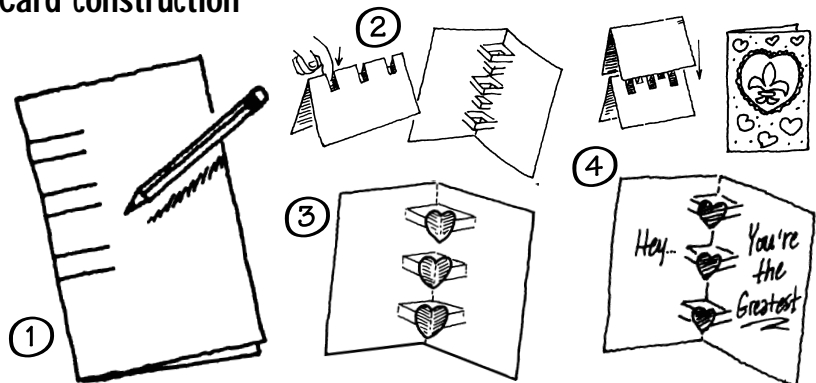

The Worldwide Web of Life

by Allen Macartney

Each year Scouting groups work hard to improve their local environments and protect wildlife. National Wildlife Week (April 7-13) and Earth Day (April 22) both occur in April. This is a great month to organize theme activities centred on protecting our natural environment.

Many Scouting groups across Canada take part in a Canadian Wildlife Federation program called Habitat 2000 which is aimed at protecting and improving wildlife habitat. For two years running, David Meerburg's 1st Carp Scout Troop, ON, has been actively involved in a local Habitat 2000 conservation program to save the River Redhorse fish. Though not a pretty fish (actually a sucker), the River Redhorse grows up to 50 cm and is classed as vulnerable. The nearby Mississippi River is virtually the only place it reproduces in Canada.

The troop chose this project because it wanted to help a local endangered species. This year the troop will meet with conservation officers to discuss the fish and learn about its place in the river's biology. Then the youth will embark on several exploratory trips to find the best location to erect warning signs aimed at educating local anglers. When they've picked ten key public access points along a 100 km stretch of the Mississippi, they'll erect semi-permanent, weatherproof signs. Each sign shows a picture of the fish, describes the species briefly and warns that anyone catching a River Redhorse should return it to the water as soon as possible.

Not only is enthusiasm running very high in the troop, but the kids are gaining a keener sense of how their actions can affect wildlife survival.

Oh Deer (Project Wild)

During a spring outing the 1st Ferris Group, ON, took part in a learning game called "Oh Deer" which demonstrates how animals depend on local



Photo: Paul Ritchie

Every creature, no matter how small, has an important role to play in nature.

food, shelter and water. The activity shows the relationship between wildlife needs and the ability of natural habitat to support them. It also demonstrates why wildlife populations fluctuate over the years.

Start by explaining the word "habitat" and talking about what deer need to survive: food, water, shelter and space. Divide your group into two — one at each end of a room or field. Both must turn their backs to each other. One group represents deer, the other habitat.

Each deer or habitat child must decide if she is looking for/representing food (put hands over stomach), water (put hands over mouth) or shelter (put hands over head). Youth must choose one of these at the beginning and not change until the round is complete.

On the count of "One, two, three" all children should make their sign and face each other. Each deer runs to the other side and finds a habitat component corresponding to its need. Any deer not finding its food, water or shelter dies and joins the habitat side. Now it is available to support the remaining deer whose survival chances have just increased.

Take Your Pick

What can your group do to improve Canadian habitat? Here are some ideas that other groups have tried:

- adopt a stream
- study a local plant, animal or insect species
- hike around a wetland taking note of plants and animals

- protect tall grasses and other plants
- mark sewer covers with a yellow fish symbol.

Ecosystems — All Strings Attached

This activity demonstrates how all parts of nature in a beaver pond are connected. You will need a handful of recipe-sized cards, markers and a long ball of string.

Sit your Beavers and Cubs in a circle. Give each child a small card with the name or image of an animal, insect or plant found around a beaver pond. Examples might include sun, soil, water, air, poplar tree, moose, dragonfly, beaver, frog, snake, songbird, heron, lily pads, tall grass.

Holding up their cards so everyone can see, one Beaver or Cub should toss the unravelling ball of string to another child whose card is directly connected through nature to theirs. For example: sun <—> tree <—> songbird <—> tall grass <—> snake <—> frog <—> water <—> heron, and so on.

When all children are holding onto the string in at least one place (some may be holding in 2-4 places), stop the game and discuss how plants and animals are all interconnected. Let the children tug gently on the string to reinforce the sense of interdependence. What would happen if the beaver disappeared? How would that affect other species?

Food Chain Mobile

This mobile not only makes an interesting work of art but it also shows how animals and plants depend on each other. For the mobile you need con-



Photo: Paul Ritch

Get right down and take a close-up look at nature. There's a lot of life even in a puddle.

struction paper, markers, string, tape and clothes hangers. Let the children draw animals, plants and natural objects (e.g. water, air) that depend on each other. Include carnivorous and herbivorous animals. Tape a short piece of string to the back of each picture then start taping the pictures together with the string. For example water might connect to a fish, then a raccoon, then a fox, then a wolf.

Fasten 3-4 food chain strings to each coat hanger. Discuss what would happen if the water was polluted and made the fish sick. How would this affect the raccoon and other animals?

Endangered Animals Jeopardy

Cubs from the 2nd Port Coquitlam Pack, BC, played this interesting game

to partly fulfil requirements for their World Conservation Badge. They started by learning the meaning of the words endangered, threatened, extinct, extirpated, and vulnerable. We wrote three of the words (endangered, threatened, vulnerable) on separate pieces of bristol board and taped them to a wall. On the floor were placed 14 pictures of animals fitting into one of the three categories. In the categories the pictures included eastern cougar, spotted owl, wolverine, peregrine falcon, sea otter (endangered); prairie long-tailed weasel, beluga whale, loggerhead shrike, burrowing owl, wood bison (threatened); trumpeter swan, great grey owl, cooper's hawk, polar bear (vulnerable).

Scouter Greg Byron then read out a statement about an animal and the Cubs had to match up the pictures to the correct poster. For instance, one statement said: "This large marine mammal is found in Arctic waters as well as in the Gulf of St. Lawrence. Pollution is a major factor affecting this animal; its main food is crustaceans and fish." When all 14 animals had been placed on the posters, Greg corrected any mistakes and read the second part of the animal identification. (One read: "An adult beluga whale may reach six metres in length. Recently a baby beluga was born in the Vancouver aquarium.") The game was followed by a discussion on how Canada was protecting wildlife.

Loon Nesting Platform

Loons prefer to live a solitary existence. Usually they nest on islands and floating vegetation, but they will also use camouflaged, man-made structures.



Photo: Jeff Austin

"We found these turtles while exploring a swamp. By fall they'll be much larger."

Make one by notching, spiking and wiring together five cedar posts (2 m x 25 cm). Staple 2 m x 2 m wire mesh to the bottom of 3 parallel logs — 12.5 gauge zinc-coated weld wire is best. (See diagram) Attach two concrete blocks to diagonally opposite corners of the platform with 9 m (#9) wire cable and four cable clamps. Position it in a sheltered bay or where thick vegetation will protect it. When the platform is in position, leave 1 metre of slack to allow for high water levels.

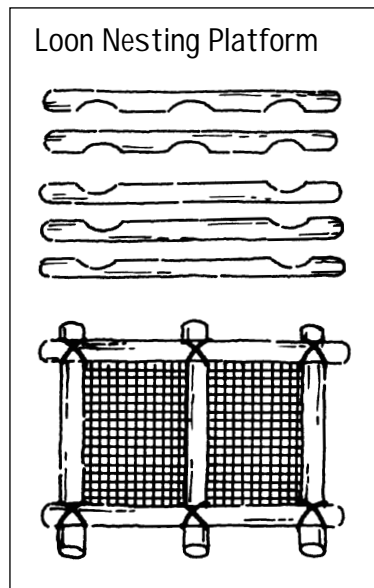

Track Record Game

This game can teach lessons of observation to any age of Scouting youth. All you need is a patch of ground or snow suitable for leaving impressions from boots, shoes or footprints.

Break up into teams. Get one team to sit with feet up in the air while the

RISKY DEFINITIONS

Use these definitions as part of your Endangered Animals Jeopardy game or just in general discussions.

- | | |
|-------------------------------------------------------------------------------------------------------------------|----------------------------------------------------------------------------------------------|
| Extinct: A Canadian species that no longer exists. | Threatened: A species likely to become endangered if changes affecting it are not made soon. |
| Extirpated: A species no longer existing in the wild in Canada but living elsewhere. | Vulnerable: A species at risk because of low or declining numbers. |
| Endangered: A species threatened with imminent extinction or extirpation in at least significant parts of Canada. | Habitat: The place a species is naturally found. |

other studies the soles of their boots, shoes or feet. After a minute the observers must turn their backs while one person from the other group makes footprints in a patch of snow or ground. Observers must look at the footprints and try to guess who made them.

After you've played this game, take a walk in the woods looking for different animal prints. Bring along a book that will help you identify them. You might make a plaster mold of several prints you discover.

Look Around You!

Make up your own habitat improvement plan. You might decide to grow a bee and butterfly garden (see the March **Leader** for details, p.15). Or you might plant wild flowers like asters, orange hawkweed or chicory along a forest path. Set up feeders and nesting areas near your Scoutree planting project to encourage birds and other wildlife to use the area. Create an interpretive trail through a nearby

park. Conduct a wetland dweller survey and identify types of frogs, water bugs, turtles, otters and salamanders.

Nature offers an endless array of fascinating projects for spring and summer. Get your group outside to enjoy it. They'll soon discover that we're all connected to the worldwide web of life. X

Resources

- The Canadian Wildlife Federation (CWF) has many resources and project ideas relating to habitat. Get your free Habitat 2000 kit by writing them at: 2740 Queensview Dr., Ottawa, ON, K2B 1A2, 1-800-563-WILD.

Program Links

Cubs: World Conservation Badge, Observer Badge, Naturalist Badge, Canadian Wilderness Award, Black Star, Purple Star.
Scouts: Naturalist Badge, Scoutcraft Badge, Conservation Badge.



Photo: James Rutlack

As part of their adopt-a-park project, Cubs and Scouts from Regina's 83rd Group, SK, helped design and build an environmental education centre. It stands in one corner of Rowan's Ravine Provincial Park.

DID YOU KNOW...?



- About 27,000 species become extinct each year worldwide. Over 99% occur because of humans. Habitat destruction is the No. 1 cause.
- Every hour 100 hectares of natural habitat disappears.
- The number of species on Canada's endangered list has grown from 54 in 1982 to an incredible 264 in 1994.



CJ'97: See You At the VSP

by Terry Lambert

Calling all Venturers and advisors!

Looking for a new kind of adventure? This one will not only develop and use leadership skills, but will let you really experience events at CJ'97 in Thunder Bay, ON. If this win-win situation sounds good to you, it's called the **Venturer Service Program (VSP)**.

Scouts Canada is looking for 200 Venturers and 25 advisors to take part in this Program the week before CJ'97 right on the jamboree site. After completing it, you will be placed as an adult Offer of Service in a specific area of the jamboree, participating as staff throughout the event.

The Venturer Service Program will prepare you to work with youth at the jamboree. It will reinforce and broaden your communication and leadership skills, and help you develop the confidence necessary to do a good job. During the week you'll become familiar with the site and meet those who you'll be working with throughout the jamboree.

Opportunities A-Plenty

You could serve in many areas (both on- and off-site), including overnight hiking and canoeing trips, waterfront activities, and a Fort William adventure. You could help guide others in canoes down rivers that famous voyageurs once travelled, or you could escort people through Native Canadian villages at the jamboree.

Are you interested in fly fishing? The Venturer Service Program will offer you some of the greatest teaching experiences available. Plenty of trout are just waiting to clamp onto your hook in northern Ontario.

Have you ever tried mining? In a world famous amethyst mine you'll search for this expensive mineral — a 'gem' of an adventure!

You'll visit Big Thunder, the training grounds of winter Olympic athletes, and bike on the trails. The wilderness camping areas will not only challenge your outdoor skills, but also your ability to teach others these same skills.

This Computes!

If you feel comfortable around computers the jamboree needs your exper-

tise. What an opportunity for those who know how to fix them and enter data. Some of these jobs involve working right at a subcamp or jamboree headquarters. We also need Venturers for security, fire safety, first aid, and other related tasks.

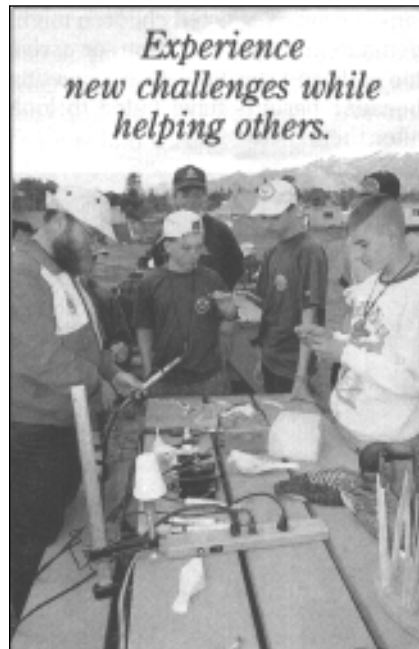

The camping site assigned to you when you arrive at the Venturer Service Program will be right at the main jamboree staff camping area — the same site you'll occupy throughout the event. Washrooms (with showers) will be available for you.

Venturers and advisors will be formed into companies of about eight youth

and one adult at the start of the Program. Meals will be provided for you at the staff dining hall or as box lunches if you're taking part in off-site activities. Buses will transport you to these areas.

Added Value

During the jamboree some program areas will remain open on specific evenings so you can experience them not only as staff, but as participants too. This is the first time that Venturer Offers of Service have been able to actually take part in various projects. This year you won't have to miss a thing!

By the time you read these words all advisors should have received an information package describing the Venturer Service Program. It should contain enough information sheets for all Venturers. If you have more questions or did not receive the package, please write to me at this address: Terry Lambert, Assistant Director Recruitment, Venturer Service Program, 710 Fern Drive, Lower Sackville, NS, B4E 1L9.

The Venturer Service Program is a worthwhile adventure for both Venturers and advisors. It lets you be part of the adult leadership team while still enjoying the benefits experienced by regular jamboree participants. Working with interesting youth from around the country is an unforgettable experience. It might also help you find a job in the future.

See you at the VSP! X

— Terry Lambert is an active Scouter living in Lower Sackville, NS.

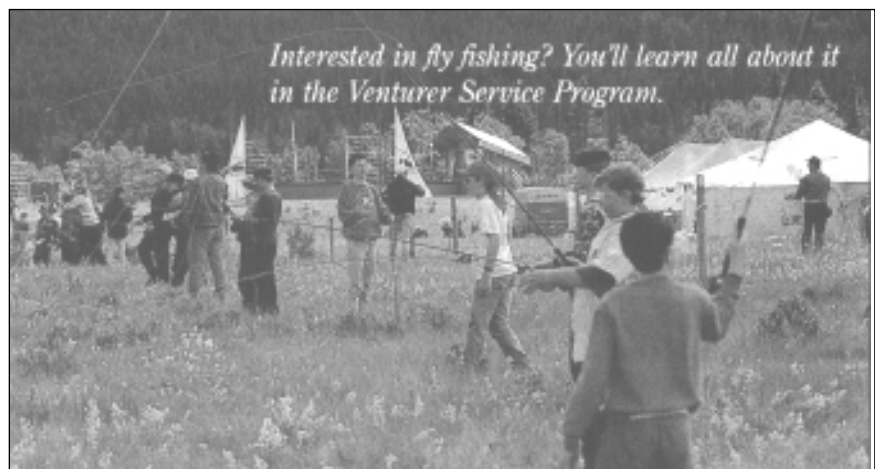

Photos: Wayne Barrett

Child Abuse

How to Protect Scouting Youth: Part 2

by Bryon Milliere

“I have a secret.”

Children are always telling secrets. There's mystery and adventure in knowing one. Secrets are fun and part of growing up. But what happens when a child approaches you and shares a terrible secret involving some form of adult abuse? What should you do? What are the warning signs you should look for?

Part 2 of our series will discuss these questions. While you may never need to deal with this problem, as an adult trusted by children, you should be prepared for the possibility. You don't need to be an expert to help a child in potential danger, but you do need to take action.

How to Recognize Abuse

Neglect, emotional deprivation, physical abuse, or sexual maltreatment that can result in injury or psychological damage to a child are all forms of abuse.

The presence of the following indicators without appropriate parental concern may indicate a child at risk. At registration time find out about special medications your Scouting youth are taking. Have parents told you about a problem they are helping the child work through? If you have any questions, always ask.

Neglect

Neglect involves chronic inattention to the basic emotional and physical needs of a child. Because the condition develops over time, people often feel a lower sense of urgency. But don't ignore it! Neglect can affect every facet of a child's maturing process and cause serious long-term psychological, and other health, problems.

Factors that might indicate neglect include: poor physical hygiene, listlessness, unattended medical needs, inappropriate clothing, and inadequate supervision. Neglected children might demand constant attention, or arrive too early and stay too late at a meeting because parents have failed to look after them.



*Most leaders and parents are caring,
loving adults working hard to
build healthy youth.*

Photo: Yancy Chow

Some of these factors in isolation may not necessarily indicate neglect. Get to know the parents and children of your group so you can distinguish between patterns and exceptions.

Emotional Abuse

Emotional abuse destroys a child's self-image and causes disabling behaviour. It is caused by adults unwilling (or unable) to provide appropriate care,

control, affection or stimulation. Constant criticism and demeaning is a common form of emotional abuse. This might involve making inappropriate demands upon a youth. A child exposed to family violence can also be emotionally harmed.

Some factors that might indicate emotional abuse include: sleep disorders, speech difficulties (because of anxiety), and frequent complaints (e.g. headache, nausea, abdominal pain). Warning behaviour might include: conduct inappropriate for the age, disruptive extremes (e.g. aggressiveness, anger, hyperactivity, depression, withdrawal), overly compliant behaviour (too well mannered, unusual need to please adults), excessively high standards, unusual fear of consequences of actions (often leading to lying, self-deprecation).

Physical Abuse

This entails physical harm inflicted by a parent or someone with authority over a child. It might involve over-discipline. *Injuring a child is not acceptable*, regardless of differing cultural standards of discipline. Children have clear rights under the law and must be protected.

Some signs of physical abuse include: unexplained bruises, welts or abrasions, unexplained small circular burns (from cigarettes), unusual rope burns, immersion (or patterned) burns, and unexplained delays in seeking medical attention. You should question all injuries that are inconsistent with the child's age and developmental phase.

Behaviour to look for might include: fear of going home, wariness of adults, behaviour extremes (e.g. aggressive, withdrawn), no attempt to seek comfort when hurt, role reversal (the child tries to care for the parent), cringing or flinching if touched unexpectedly, absence of parental support, inappro-

priate dress (perhaps to cover injuries), or an uncharacteristic change in participation during physical activities.

Sexual Abuse

Sexual abuse is one of the most difficult forms of mistreatment to identify because the abuser is often well known to the victim and has frightened the youth into "keeping the secret." Sexual abuse occurs when an adult with authority over a child misuses this power for the purposes of exploiting the youth for sexual gratification. Criminal behaviour in this category includes incest, sexual molestation, sexual assault and exploitation of a child for pornography or prostitution. (Sexual activity between children may constitute sexual abuse if the age differences or the relationship between them leads the older one into taking sexual advantage of the younger.)

Factors that might indicate sexual abuse include: physical signs on the external genitalia, vaginal or anal areas (e.g. swelling, itching, bruises, bleeding or lacerations), pain during urination, pain that leads to difficulty when walking or sitting, and recurring vaginal infections or sexually transmitted diseases (especially in pre-adolescents).

Watch for these behaviour patterns: fear of normal physical contact (especially when initiated by an adult), sexual aggression, promiscuity, reluctance to participate in physical activities, unusual knowledge of sexual behaviour, confusion about identity (e.g. love, care-getting and care-giving), self-mutilation, severe depression, or dramatic behaviour changes.

Who Must Report

Every person who believes on reasonable grounds that a child is, or may be, in need of protection *must* report promptly this belief and any supporting details to the local child protection agency. Every province has similar child protection laws. Consult your local police.

In some provinces *it is a criminal offence for professionals and volunteers who provide youth services NOT to report suspected abuse.*

It isn't your role to investigate suspected abuse. In fact, your probing inquiry may jeopardize the investigation by authorities. A child protection agency will need to know the youth's name, address, telephone number and date of birth, as well as details of the disclosure in the child's words. Record

Scouting programs give kids opportunities to grow in a safe, happy environment.



Photo: Rose Bealeman

dates, time and location of events where available, but do not interrogate the child. Note any injuries and/or other signs of neglect.

Protection from Liability

If civil action is brought against a person who made a report, the law protects the person unless he/she acted maliciously or without reasonable grounds.

Well-Balanced Perspectives

As a Scouting leader, don't get overly sensitized to child abuse issues. Scorpions are not found under every bush. The vast majority of parents and adults are responsible, caring and loving guardians, wishing (and doing) the very best for their children. However, if you do have concerns, act on them. A child's welfare may be at risk.

Resources

- The National Clearinghouse on Family Violence (Health Canada) has a lot of information about abuse. Please call 1-800-267-1291.
- *Put the Child First.* This booklet is available at council offices. ^

IF A CHILD DISCLOSES ABUSE

1. *Listen* very carefully, believe what the child says and acknowledge his/her feelings.
2. *Follow* what the child says; don't lead.
3. *Restrain* your own natural reactions of horror, revulsion, anger, etc.
4. *Assure* the child of protection.
5. *Emphasize* that he/she is not to blame for the abuse.
6. *Remind* the child of your continued caring.
7. *Prepare* him/her for the steps you will take (reporting the abuse, etc.)
8. *Seek* expert guidance and support for yourself.

— Thanks to Ron Ensom, MSW, CSW, Ottawa, ON.



SCOUTING'S MISSION STATEMENT



To contribute to the development of young people in achieving their full physical, intellectual, social and spiritual potential as individuals, as responsible citizens and as members of their local, national and international communities through the application of our Principles and Practices.

Wow! What a Successful Recruitment Campaign!

by John Rietveld and Rick Kawai



Photo: Paul Ritchie

If you're hoping to increase youth membership next fall but want to try a more dramatic approach, listen to this. Hamilton Wentworth's Regional Council in Ontario has a highly creative and successful program.

How good is it?

This year their youth membership increased by over 10%. Next year they expect further growth. Their method is inexpensive, but requires advanced planning and hard work to build up an effective network of key people in the community.

Scouting enrolment activities normally follow similar patterns across the country. Some time after Labour Day various sections contact last year's members and inform them of registration night details. They answer questions like: When? Where? How much will registration cost for the coming year?

The previous year's members arrive on registration night with parents following closely behind to write out the cheque and fill out forms. A few of last year's kids bring along a friend. Great. Other past members come alone. Some don't show up for several weeks. In many cases, they don't show up at all.

Some groups send notices to their neighbourhood schools or ask local churches to draw attention to Scout registration in weekly bulletins. More aggressive districts take out newspaper advertisements announcing that their registration has begun and listing the location of groups and contact numbers. Despite all the efforts, membership often continues sliding downward. Leader moral sometimes follows.

Try telling every elementary school student in your region about neighbourhood Scouting opportunities.

High Speed Membership Growth

Last fall Hamilton Wentworth Region tried something dramatically different with magnificent results. Not only has the Region experienced revitalization, but it's also enjoying rapid growth in both new youth and adult members.

Repeated membership declines: these words described Hamilton Wentworth's situation for years, as they do

many other regions. Usually, efforts to boost membership began in the winter after the fall registration statistics had been compiled and the bad news had finally reached the management committee.

Last February the Region once again faced the frustrating reality of declining numbers. After discussions, most agreed that trying to recoup lost members over half way through the season was difficult and rarely resulted in significant growth.

Across the country about 90% of Scouting members sign up in the early fall — usually September and October. Armed with this knowledge, Hamilton Wentworth decided it would be easier to stimulate growth in the fall before programs started and when both youth and parents were inclined to registration, than in the winter when sections were already well into their annual programs.

A Winning Idea

During early spring brainstorming sessions, leaders decided that one way to enhance fall registration would be to give all local students returning to school, information on nearby Scouting activities. Included would be the location of the nearest group.

Pretty simple, eh?

The Region hoped this plan would reach large numbers of youth and get most of last year's members back,

while also picking up a few more from each school. If successful, the leaders thought it wouldn't be too hard to meet, or exceed, the previous year's membership in each group.

Soon a plan was developed that matched existing groups to nearby schools; it also targeted these schools with special promotions during the first two weeks of September.

For this recruiting drive, the Hamilton Wentworth Region was divided into eight areas. During the summer a different flyer was developed and printed for each area. Each flyer contained an overview of Scouting's sections, a map of the specific area showing where each group was located, meeting night/location for the sections and registration times for the groups. Then 34,000 flyers were printed and collated for each of the Region's schools based on projected registration numbers obtained from the school boards. A coordinator was recruited for each area and was responsible for hand delivering a package of flyers to the schools during the last week of August.

The objective was to tell every elementary school student in the Region about Scouting opportunities in their own neighbourhood.

Ambitious Targets

The program targeted a total of 136 schools in their Region. Coordinators advised all groups to (1) expect a significant increase in youth registrations and (2) prepare by increasing adult leader recruitment efforts for fall registration.

By the end of October the Region's youth membership had increased by 18% over the previous year's fall totals. Overall membership rose by 14%. After tallying the results and including late registering groups, the December 31st youth registration had risen 10% over the previous year. Overall membership realized a 7% gain. Fourteen waiting lists held the names of other youth wanting to join Scouting sections.

Let's all do our best to make sure every child who wants to belong is given the opportunity.



Recruiting posters and brochures are available through local council offers.

The recruiting campaign's cost was low — about \$3,500. It was time consuming for organizers to plan the first project, but future campaigns will require less effort. Why? Location maps are already drawn, contacts are in place with school principals and organizers have gained a lot of experience from last year.

Publicity

Scouting got its message out to the public using four basic methods:

- radio
- PSAs
- cable television billboards
- community and daily newspapers.

Letters were sent to Directors of Education in May to obtain approval for the recruitment project. Principals were notified in June; another letter followed up in August.

Future Plans

Hamilton Wentworth has already started to plan for this fall's recruitment campaign. More principals will be asked to distribute flyers direct to the students. (In 1995 some just made them available in school hallways.) The 1996 project will also target leader recruiting at the group and regional level for September.

Move to the Fast Lane

Whether you're the publicity person for a group, or the PR chair for a district, the ideas used in Hamilton Wentworth can work for you too. Scouting is a great Movement; let's all do our best to make sure every child who wants to belong is given the opportunity. Start planning your fall registration now! X

— Rick Kawai is Chair of the Hamilton Wentworth Regional Membership Management Committee.

Tunnel Vision:

Discover A World Down Under

by Brenda Corie

What would you think if your Scouts or Venturers decided they wanted to go caving? Rather than panic, excited anticipation might be a more appropriate response.

Underground you'll see spectacular stalactites and stalagmites, as well as occasional columns. Each cave is different. Some passages will be dull, while others will lead to beautiful chambers. You may come across "soda straws", delicate straw-like structures hanging down formed by years of dripping mineral water. Unfortunately, some people snap them off as a souvenir.

Caves are more than just dark, empty holes in the ground. They are home for a number of creatures including bats, packrats, birds, mice, snakes and insects. Use the experience to study their natural cave habitat. Take a water sample and compare it under a microscope to a sample you find just outside the cave's mouth. Make a list of all the

plants growing just inside the cave mouth. Do you find any deep down a passageway? Look for fish and little insects living in pools. Can you identify them?

Our group has encountered many bats and packrats in our subterranean

debris — not to mention their feces and its accompanying aroma.

Bats and caves go together well. Don't be afraid of them swooping down upon you, trying to nest in your hair, or seeking to bite your neck. Our Scouts and Venturers have seen bats in every cave we've explored, but invariably we've been far more interested in them than they in us. Voracious eaters of insects, possessing a sophisticated radar navigation system and an absolutely fascinating reproductive biology, these flying mammals deserve our utmost respect. One of the more interesting finds of our Scouts was a well-preserved pile of tiny bones — the skeleton of a brown bat lying on the cave floor.



Water carved this tunnel out of rock.

travels. Packrats prefer areas near the cave mouth. Whatever treasures you leave lying around here, a packrat might just sneak them away. Be forewarned. You'll detect their presence by nests and

and guide your expedition. He knows the hazards to avoid and won't get you lost. Outdoor clubs or stores will be very helpful identifying one or two who fit well with your group. Make sure the guide is environmentally sensitive and willing to work with youth.

Take at least several meetings to prepare for your underground adventure. Let your guide explain precisely what you'll do; take time to answer any questions and concerns. Make sure parents know *exactly* what you plan and where you're going. Ask several to help out on the trek.

Your first caving experience should be a short hike through a large, well-known cave. As everyone gains confidence and experience, advance to more challenging adventures, but *never* take risks. Practice walking around with your eyes closed. You never know when you'll find yourself in total darkness.

When you're more experienced and ready to explore caves with multiple passageways, mark your way at junctions with a cairn, not string or paint. Pile sev-

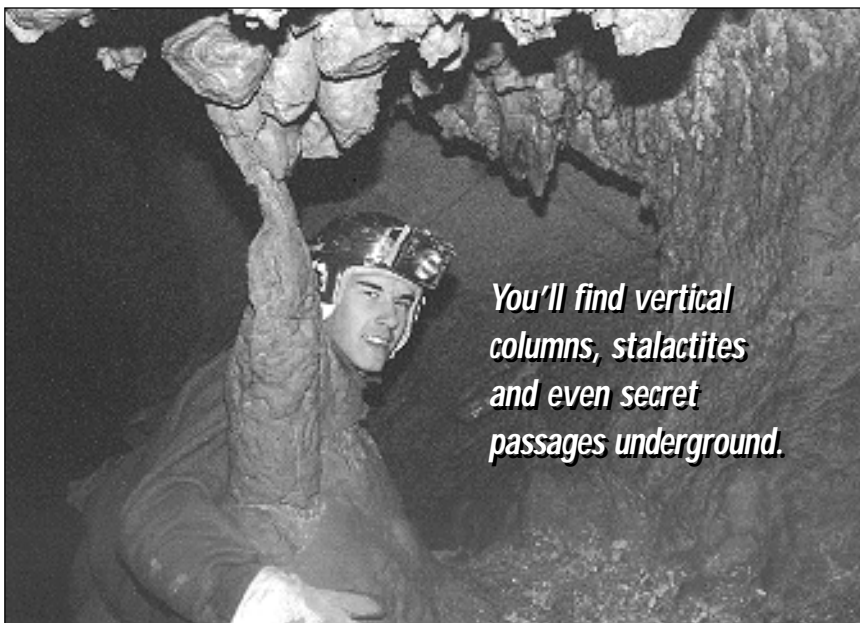

You'll find vertical columns, stalactites and even secret passages underground.

eral rocks to indicate your way, then when you return put them back in their original location so other cavers will never know you've been there.

“This is really cool!”

Caves are cold regardless of the season. Interior temperatures generally remain just several degrees above freezing. Bring warm clothes including caps and possibly scarves.

Caving almost always involves taking a considerable hike to reach the starting point of your adventure, so restrict it to those 12 years and older.

Caves are dark. Once away from the entrance and its light source, you will experience *total* darkness. It's a powerful feeling to turn out your head lamps, let your eyes adjust to the darkness and then to hold your hand in front of your face. You'll see *absolutely* nothing — another reason to restrict the adventure to older children.

Caves are very damp and often muddy. Their floors are frequently slippery. Move slowly and carefully as you pick your way through them.

What to Take Along

Here's a list of important equipment that our troop brings on every trip.

1. *Protective headgear:* Everyone must wear this — absolutely no exceptions. The rocky walls of caves are very irregular. A hard hat or hockey helmet works fine, but it must have a chin strap. You'll be amazed at how often your head will strike cave walls.
2. *A light source:* Purchase head lamps from a safety supply shop (about \$5/each). Ours have bright krypton bulbs and work with a pair of “C” batteries. Tape the batteries to the helmets with duct tape.
3. *Spare batteries:* We require everyone in our group to come with two sets of new batteries.
4. *Gloves:* Garden gloves with leather palms work well. I put a pair of old wool gloves inside for greater warmth. Inexpensive, lined, water-proof work gloves are even better.
5. *Proper footwear:* Cave floors are slippery, so you'll need lightweight hiking boots with wool socks. Extra dry socks might come in handy, especially if your cars are parked a long way from the caves.
6. *Old clothes:* A pair of coveralls is ideal. Bring them with a plastic garbage bag inside your pack. Wear the coveralls over an old sweater and a pair of pants. After your caving adven-

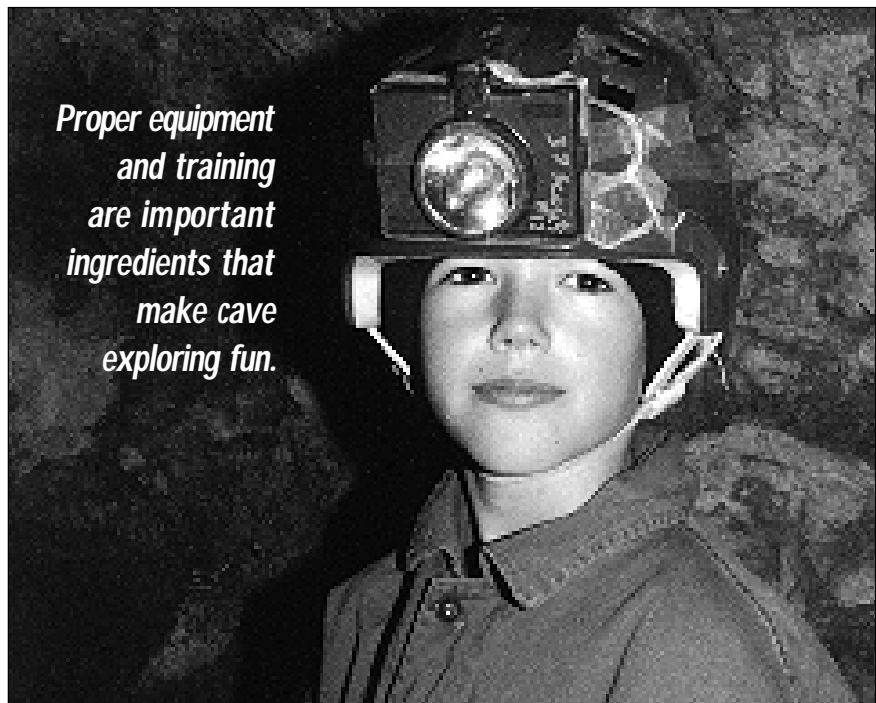

Photos: Brenda Corie

*Proper equipment
and training
are important
ingredients that
make cave
exploring fun.*

ture, take the dirty coveralls off at the cave entrance and put them in the plastic bag.

7. *First aid kit:* One leader in the group needs to pack a compact, but complete, kit. Any minor first aid problem is made worse because you are underground. Tricky squeezes and crawl spaces make for a difficult rescue. Prepare for problems long before you go underground.
8. *A light stick:* These plastic sticks are available commercially; they provide a safe, reliable light source for 8-12 hours. Keep them for emergencies.
9. *Snacks and water:* A snack inside your cave really adds to the adventure. Bring it along in a backpack, as well as any refreshments you want. Never drink any water found in or near a cave. It can be dangerously polluted by bat droppings.

Tie your caving trek into other program activities. It fits well with themes like first aid, rock collecting, hiking and wildlife habitat studies.

Exploring dark caves and listening to dripping water isn't for everyone. But if your Scouting youth want to try it out, give them a chance for an adventure of a lifetime. X

Program Links

Scouts: Troop Specialty Badge, Explorer Badge
Venturers: Exploration Activity Award, Outdoorsman Award

— *Brenda Corie from the 37th LDS Scout Group in Edmonton Alberta, likes taking youth on caving adventures.*

CAVING ETIQUETTE

Though caves might take thousands of years to form, a *single person* can quickly cause irreparable damage. Many easy-access caves are now little more than damp holes in the ground — their original beauty long ago destroyed. Do your very best to protect the cave wildlife habitat by following this advice.

- Take only pictures and leave only footprints. Tread lightly; even your footprints can damage.
- Pack out *everything* you bring. Better yet, bring a garbage bag and clean up any litter you discover. You'll find plenty of old batteries, cans, string and plastic.
- When you look at cave animals, do it carefully. Disturbing a hibernating bat in winter causes it to use up precious fuel reserves. Your curiosity may cost the little animal its life.
- Never yell in a cave; it might disturb animals living in it. Appreciate the quiet.

Cub Cartoons for April Fool's

I started doodling with the Wolf Cub head emblem during a regional meeting and suddenly came up with a neat program idea. The fun faces have many uses: a gathering activity, rainy camp project, Halloween masks. Here are some ideas.

- Make up several faces from the designs (see examples). Get Cubs to colour and glue one onto stiff cardboard. Let the glue dry, then, helped by a leader, cut the face out into puzzle pieces. A puzzle competition between sixes would get the adrenaline flowing.
- Reproduce all of the Cub faces shown here. On a separate sheet write down all the names for the faces. Working against the clock in teams, Cubs must put a face to the name.
- Make up a number of small Cub heads, apply glue to the back and use as a custom letter seal.
- With Cubs standing ready with sketch pads, ask your group these questions. What do Halloween Cubs look like (pirate, gangster, bandit, pumpkin)? What would a Cub who hadn't slept at camp look like? How could you show a Cub blowing bubble gum? How could you represent world Cubbing? How could you show these expressions: worried, wow!, sick, puzzled, scared.
- Think up (or match up) titles to the twin cartoons drawn below. ("You're standing on my foot!" "Can my sister join?" "I feel sick doc." "Guess who was on TV?")

Let your Cubs think up their own games with this cartoon activity. They're sure to have a ball!

Program Links
Cubs: Artist Badge, Tawny Star #9

— Jim Lloyd, Fairvale, NB.

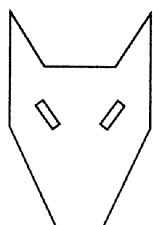

Normal Cub

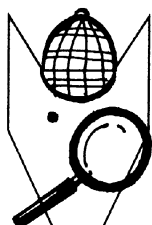

Sherlock Holmes



Lone Ranger and Tonto

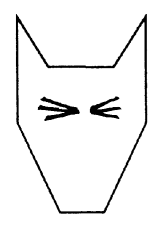
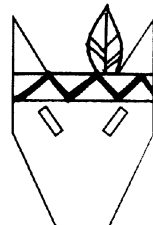

"You're standing on my foot!"

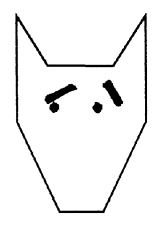

Rambo

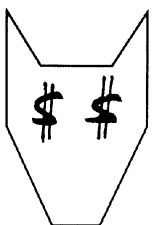

Fundraising



Lancelot and Guinevere

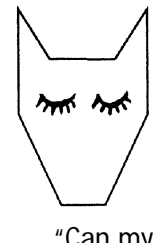
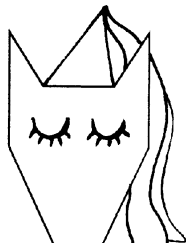

"Can my sister join?"

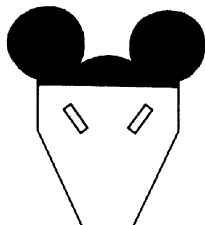
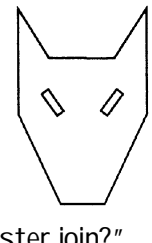

Mickey Mouse

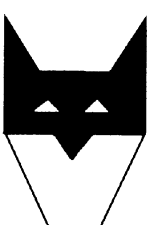

Batman

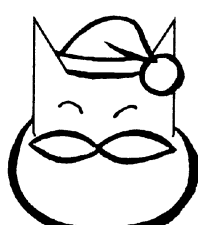

Santa Cub

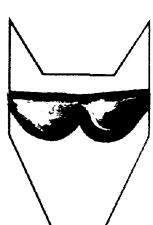

Cool

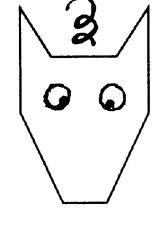

"I feel sick doc."

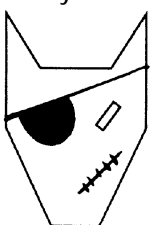
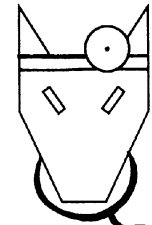

Pirate

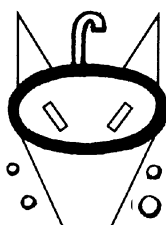

Scuba Cub

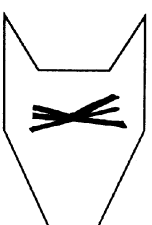

Noise

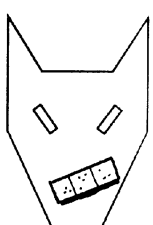

First Aid Cub

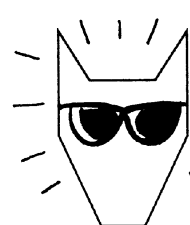

"Guess who was on TV?"

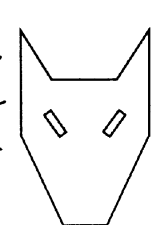

Have Stove, Will Travel

Scouts from the 2nd Armour St. Lukes' Group in Peterborough, ON, couldn't go camping without their Can-Cook 75 stove. Several years ago everyone made one during a Gadget Day.

To build a Can-Cook 75 you need paraffin wax, a double boiler (to melt the wax — see details below), oven mitts (for pouring melted wax), corrugated cardboard strips and coat hanger wire.

Each stove requires a collection of tin cans. These include,

- a tuna/salmon tin (fuel container)
- 284 mL soup can (for boiling tea/cooking food)
- 681 mL juice tin (the body)
- 1.36 mL large diameter tin (a base).

The tools you need include pliers (to cut the coat hanger wire), "V" can opener punches (for making holes in tins), a regular can opener, electric drill, a nut and bolt (7 mm x 1 cm), 7 mm drill bit, and an extension cord.

Construction

Drill a small hole in the centre of the tuna tin and the base tin. Insert a 7 mm bolt through both holes and tighten the nut by hand.

To make the fuel cell, tear the corrugated cardboard into strips just slightly narrower than the depth of the tuna tin. Use scissors to trim the bottom if necessary, but leave the top edges jagged. These jagged edges will form the wick. Place the strips in the tin, starting at the outside edge and

working inward toward the centre. Don't pack the cardboard too tightly; leave room for the wax.

Melt the wax in an old pot that you don't mind throwing out. (This is the central part of your double boiler.) Place it *inside* a larger pot (the outside part of the double boiler). Put 8-10 cm of water in the larger pot and boil the water with the smaller pot nestled inside holding the wax chunks. This double boiler will ensure the wax doesn't ignite while melting.

Pour the melted wax into the tin can with the cardboard strips, filling all the crevices. Leave a little cardboard showing at the top not covered by wax (about 2 mm). This will be the wick. If you char the wick by igniting the cardboard and then put it out, the wick will be easier to light on the trail.

Prepare the stove by punching "V" holes (for draft) in the base of the 681 mL juice tin. Remove the bottom of the tin. Using the drill, make many holes at the approximate height of the fuel tin. These will provide for a cleaner burning fire (paraffin wax often burns with lots of smoke) and will increase heat levels.

Cut and bend two coat hangers to make grills. With the electric drill, make holes in the 681 mL can (see diagram). Let your Scouts or Venturers test their stoves by boiling water for hot chocolate. X

Program Links

Scouts: Exploring Badge (Bronze 5), Winter Scouting Badge (Silver 1), Scoutcraft Badge.

NATIONAL NEWS

Mark these coming events on your Scouting calendar.

■ The next meeting of National Council will take place on Saturday, May 11, 1996 in the Delta Airport Hotel, Toronto, ON. Discussions start at 9 a.m.

■ The National Conference for Executive Staff will take place at the Banff Conference Centre, AB, June 8-14, 1996. Dr. Jacques Moreillon, Secretary-General of the World Scout Organization, will address the Conference.

■ The 6th World Youth Forum will be held in Moss, Norway, July 2-5, 1996. Steve Kent (Newfoundland) and Laura Wilson (British Columbia), both members of the National Youth Committee, will represent Canada at the Forum.

■ The 34th World Scout Conference will take place in Oslo, Norway, July 8-12, 1996. Our Canadian delegates will include the International Commissioner, the Chief Executive, the Executive Director of the International Relations Service, Adam MacKenzie (youth delegate), and two members of L'Association des Scouts du Canada. Also attending as official observers will be Stephen Kent, Laura Wilson, Geoff Wheatley (former Chair of the Interamerican Region), and Ralph Ross (current Chair of the Interamerican Region Program Committee).

■ The 10th World Rover Moot will be held in Ransäter, Sweden, July 15-16, 1996. The Canadian Contingent will be led by Rover advisor Paul Mozsar from British Columbia. X

Can-Cook 75 Stove

Fuel tin

Fuel tin made from tuna can. The fuel will burn about 2 hours.

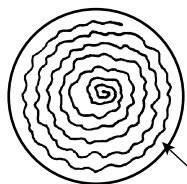

Charred cardboard 2 mm from top of can.

Pot for cooking

681 mL tin

Coat hangers bent and cut to make grill. Two optional grill positions are shown. These will give you two heat range choices.

Multi air holes around base provide cleaner and hotter burning fire.

"V" shaped holes made from a can opener.

Nut and bolt (7 mm x 1 cm)

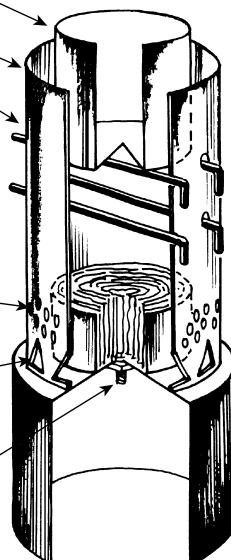

Fun at the Pond

by Lena Wong

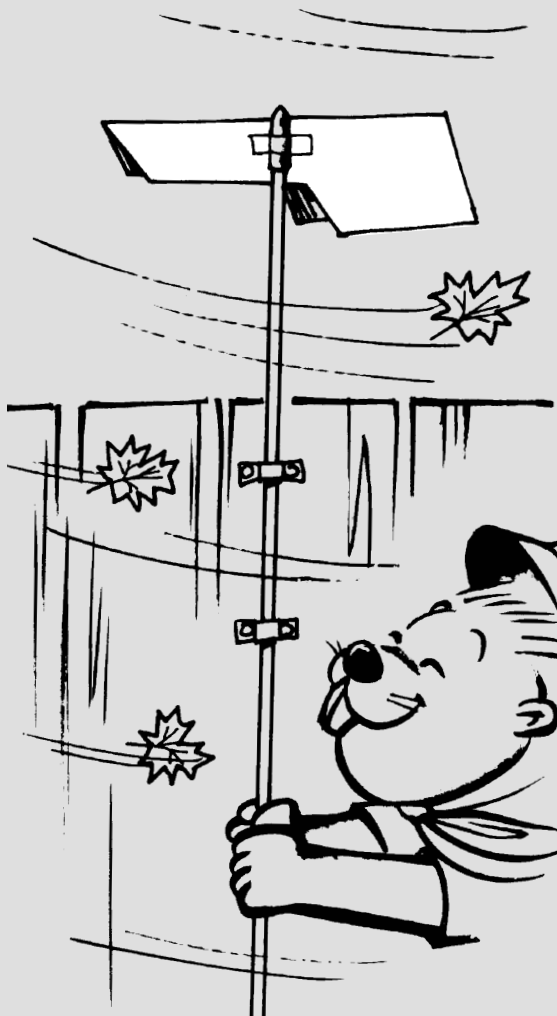

Have you taken advantage of the awakening spring by getting your group outside to enjoy nature? Here are some ideas to get you started.

April 22 is Earth Day. What a great reason to study, discuss and learn about the outdoors and our environment all month. Plan a Saturday morning outing to explore a nearby park, bush or nature trail. Farmlands are also great locations to explore.

Plan your outing fully to make the most of it. In addition to a camera, bring along magnifying glasses, pencils, crayons, paper and guide books about birds, plants, trees and insects. Remind your Beavers to wear appropriate clothing for the trip. Mud, water and even snow patches are still present so a raincoat or jacket, mittens, a hat and rubber boots might be good to have. Encourage your Beavers to bring a small backpack for the extra clothing, and possibly a snack and drink.



Responsible Stewards

At a meeting prior to the outing, speak to the Beavers about how they can help preserve and protect the area you plan to visit. Talk about the damage caused by picking wild flowers, breaking branches off trees and trampling through undergrowth without regard for tiny trees or other fresh growth.

At the park or nature trail, split into small groups taking as many separate paths as possible. Make sure everyone knows where and when to meet for joint activities. As you walk along your path, stop often to study the things you see — animal tracks, bird nests, plants and insects. Look for anything fresh and green: spring's messengers. Make rubbings of tree bark, fallen leaves, large rocks, lichens and anything else that interests the children. Use the magnifying glasses to study things you find. Draw pictures and include these in a scrap book with the rubbings of other treasures you find.

CASTLES IN THE AIR

Since April abounds in wind and clouds, you could study weather this month. Look in your library for *Usborne Science and Experiments — Weather and Climate* (Usborne Publishing, 1992). Discuss how clouds are formed, look for different types, and talk about what they mean. Why are rain forests and rivers important in the production of clouds? How does rain make things grow? Discuss the implications of draining lakes or burning rain forests. How do man-made lakes affect the environment?

Demonstrate cloud formation with this little experiment. You need a large glass jar, a small metal tray and some ice cubes. Pour about 2.5 cm of hot water into the jar. Place the metal tray on top of the jar and put the ice cubes in the tray. As the warm air inside the jar rises and is cooled by the ice, the water vapour is condensed into droplets running down the sides of the jar.

Cloud Craft

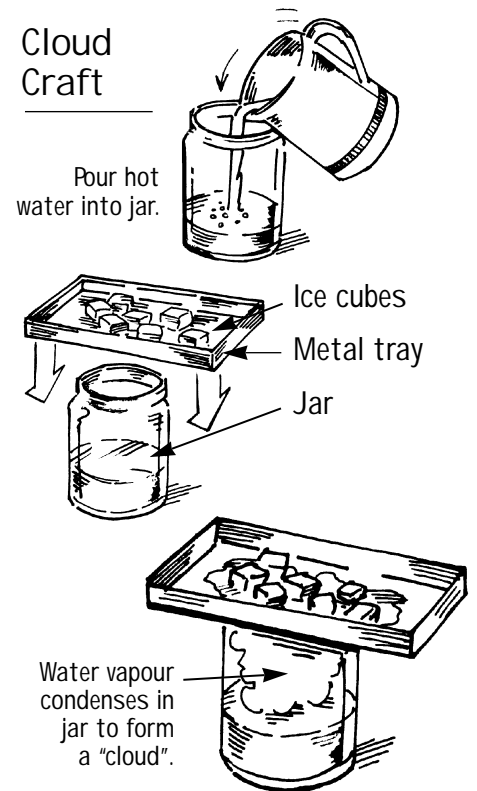

Have a short, simple discussion about air pressure and how winds are formed. Talk about different wind speeds and how they feel on your skin. For example we can feel a light breeze (6-11 km/h) on our faces; it will make leaves rustle. A strong breeze at 40-50 km/h will move large branches on trees and turn umbrellas inside out. A hurricane (118+km/h) will destroy some trees.

Make a wind vane

A wind vane shows the direction of air movement. Beavers will enjoy making one for their own backyards. To make a wind vane you will need thin cardboard, adhesive film for covering books, a 1 metre length of dowel 5 mm thick, glue, strong tape, two metal clips large enough to encircle the dowel and a lid from a disposable pen.

Draw the outline of the wind vane on the cardboard and cut out. (See diagram) Cover one side with the plastic film and score a line down the centre. Fold the vane in half, stick the halves together with the plastic covered side out, and cut across the narrow end to make a pointer. Use tape to stick the pen lid to the vane. The Beavers will need an adult to help them with the installation of the weather vane. (Give them a sheet of instructions to take home.) Hold the dowel against a wooden post or edge of a fence and attach it with the cable clips so the dowel can't turn. Place the vane on top of the dowel. Now your Beavers are ready to follow the wind. A parent or older siblings can point out north, south, east and west in relation to their wind vane.

Wind Vane Construction

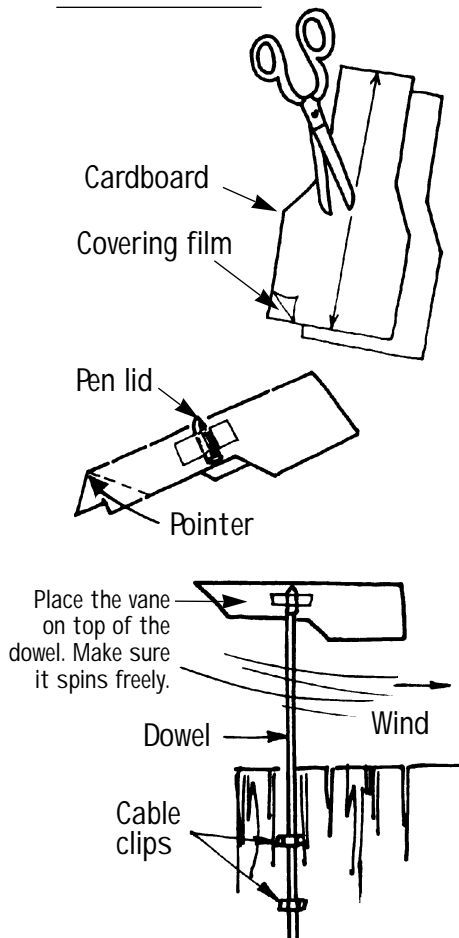

OUR SENSES

Discuss this subject in relation to humans, animals and plants. Some of these ideas will take preparation but they'll help your Beavers understand nature better. A good resource is *Usborne Introduction to Biology*, (Usborne Publishing, 1984).

Light

All living things are sensitive to light. Borrow a book from the library showing how our eyes work. Demonstrate this to the Beavers by turning the lights off in your meeting room and making it as dark as possible for a couple of minutes. Sing a song during this time. At the end of the song, turn the lights on and ask the Beavers how their eyes reacted. Now talk about different kinds of eyes such as those of insects, cats and owls. Did you know that dragonflies have nearly 30,000 lenses in each eye and that bees can see ultraviolet light? Why can cats and owls see in the dark and why is it useful for owls and other night animals to have such huge eyes?

Demonstrate how plants respond to light by growing a few seeds in a seed tray, placing it in a bright sunny window. Do not turn the tray when the plants start growing; allow them to turn to the light. Bring the tray to a meeting and show the Beavers how the tiny plants have grown; draw arrows on the sides of the tray to show the direction the plants were growing. During the next week, turn the tray the other way and bring it to the following meeting to show how the plants have changed direction.

Sound and vibration

Explain to your Beavers that sounds are really vibrations travelling through the air. Animals with large ears, such as bats, hear very well. Borrow a book

about bats from the library and study these small interesting mammals. Animals with long whiskers like cats, mice and gerbils are sensitive to vibrations in the air. They use their whiskers to help them locate sources of vibrations. Fish don't have ears; they pick up vibrations through cells running the length of their bodies.

Demonstrate sound and vibrations with a comb and waxed paper. Ask your children to bring a small plastic comb to the meeting. Folding a piece of waxed paper over the comb's teeth, Beavers should place it against their lips and blow over the paper. This will start a vibration which will create a sound. They can feel the vibrations on their lips as a slight buzzing sensation.

Smell and taste

Noses and tongues are very important to all animals, including people. Most animals have a better sense of smell than people; this helps them find food and avoid predators. Insects actually smell with their antennae, while flies taste through their feet! This is why they walk over their food before they start eating.

Smell and taste experiments can be fun. Bring in different substances for the Beavers to smell while blindfolded. Can they guess what it is? You could even make a map of your tongue. How? Prepare solutions of sugar water, salt water, vinegar and black tea. Dry your tongue with a tissue and place a drop of one of the solutions on the tip, the sides and the back. Rinse your mouth and dry it between each solution. Make a diagram of the results and see if the Beavers all taste the same things in the same locations.

Enjoy spring. A great summer lies just ahead. ^

PARTS OF YOUR TONGUE

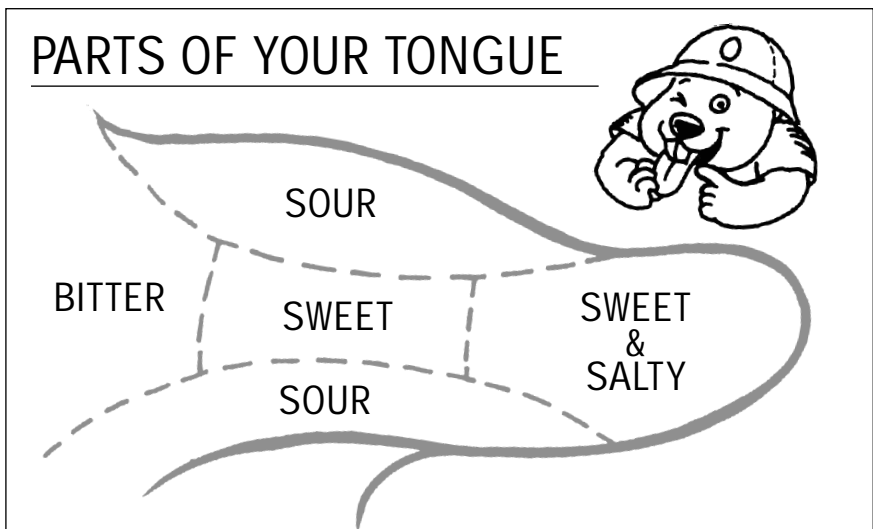

Scouting for the Whole Family

by Bryon Milliere

Children and adults who "Scout" together often develop long-lasting friendships. Why does this rapport survive long after their involvement with Scouting, even when people move out of the community? It's because our recipe for close fellowship includes common values and interests, combined with the experience of meeting challenges together.

In many families, *everyone* enjoys Scouting. In some, Scouting is a passion savored by several members without support from others. Not every person has to be fully involved for the affects to benefit the entire family.

Family Matters

How can leaders help make Scouting a family affair? Family members may have diverse interests, but share similar values. Encourage individual members to pursue their own interests and celebrate each other's achievements.

Involve children early by bringing them to activities and camps. Some groups plan family activities such as picnics and banquets. This makes everyone feel welcome. At these events, recognize leaders for their contributions and youth for their achievements; this way whole families share in the accomplishments. After all, a supportive

spouse and flexible siblings make it possible for members to pursue their Scouting interests.

Invite another Scouting family over for a barbecue. What a great opportunity to share fun stories of a Beaveree or the last camping trip! You could show photos or a recent camp video. Non-Scouting spouses might make new acquaintances. Or, as they watch their children playing with kids who share similar values, parents may better appreciate why other adults are drawn into the Movement.

Back at the Ranch

Scouters sometimes forget that while they were having a great time at a Scouting activity, weekend camp or training event, their family was living its own challenges and experiences. Before you share every minute of your weekend in vivid detail, take ten minutes upon your return to find out what happened back home. It'll go a long way to warming your home for the Scouting story. No matter how well you tell them, some stories don't make sense to a person who wasn't there. Keep those to retell over the next campfire.

Mastering a skill or overcoming a challenge brings a tremendous sense of accomplishment and boosts your self-esteem. This personal growth should have benefits for your entire family. Discussing these growth experiences with your spouse will help her (or him) understand and get involved. People some-

times find change worrisome when they don't understand it. Encourage all family members to challenge themselves in ways that help them recognize and develop their own strengths.

Too Much of a Good Thing

If you find that your family benefits less from Scouting than the kids you work with, it might be time to start saying "no" to more responsibilities. Maintain a healthy balance between community work and home life; this will foster growth in both areas.

Even your own child, as a member of the section you lead, may find she receives less attention than she did before Dad became a leader. Beaver and Cub aged children may need particular reassurance that they aren't forgotten when Dad or Mom tries to provide leadership to the whole colony or pack.

In small groups and one-to-one settings, Scouting activities can provide common interests for parent-child relationships. Working on badges together provides a great opportunity for individual attention. Other activities furnish a family experience. Why not plan a hike together for your whole family to enjoy?

Summer Hiatus

Summer provides a natural break from weekly meeting routines. Kick back and reflect on the difficulties and experiences of providing fun, safe, educational and challenging programs. Thank your family members for their support and patience. Apply some of your heightened creativity and enthusiasm to a family vacation. Those organizational skills used for weekend camps come in handy for family trips or activities.

Thanks for the Memories

You may not hear appreciation from youth and their parents until long after children leave your section. One day you'll be sauntering down the aisle in a grocery store or walking briskly down the street. A kid will stop you and say, "Hey Scouter, remember me? I was in your colony. We had a great time didn't we? Thanks."

By maintaining a balance between Scouting and family commitments, you'll ensure your family also holds fond memories of your Scouting involvement. X



Photo: Louis Looi

Use Scouting activities to spend quality time with your own child.



Book Talk

by Dave Jenkinson

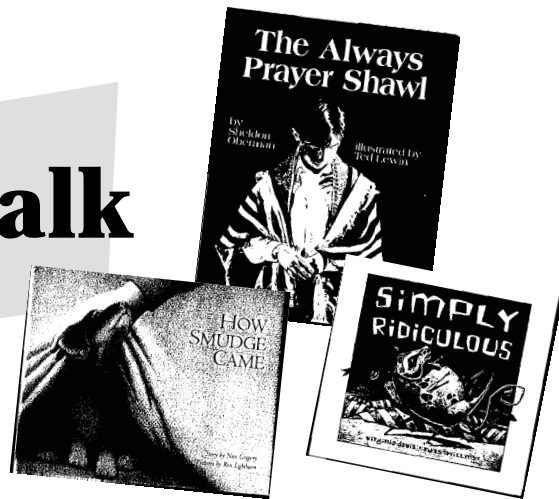

The love of reading.

Perhaps this is one of the greatest gifts adults can give children. While generally we let schools teach reading, as Beaver and Cub leaders we are "significant adults" in the lives of children; the behaviour we model can influence their actions later in life. By including reading times as part of our programs we show our Beavers and Cubs that we value its importance. Because interests vary with age, reading to small groups (rather than the entire colony or pack) will usually not only hold listener attention better, but also offer a greater sense of intimacy.

Someone whom all Beavers should meet is a loveable little turtle called Franklin. Created by Paulette Bourgeois and charmingly illustrated by Brenda Clark, Franklin has become a preschool/early school favourite because he shares so many of the qualities and concerns of this age group. The Beaver motto, "Sharing, sharing, sharing," is well exemplified in *Franklin Plays the Game*. A proud member of a soccer team, Franklin is upset because his inability to kick the soccer ball straight means he never scores goals. His animal teammates also have problems playing the game; consequently, their team hasn't won any games. Despite a supportive coach and parents, Franklin still wants the team to score a goal. They finally achieve it through a play requiring teamwork and sharing.

Although the other team still wins the game, Franklin gets a new understanding of the word "winner." Familiarize yourself with all the Franklin titles, then match your reading to what's happening in your Beavers' lives. A new gap in a smile might suggest *Franklin and the Tooth Fairy*, while a sleepover could be a great time for *Franklin's Blanket*.

Reading times also give linking opportunities. Instead of leaders always doing the colony reading, why not invite some Cubs who are working on their Reader Badge? Older Beavers should enjoy the foolish adults found in Virginia Davis' *Simply Ridiculous*, a retelling of a traditional tale with zany illustrations. When a young man's wife is going to have a baby, he wants to know, "What kind of child will we have?" Since his wife cannot tell him, he seeks out the Wise Old Man who says, "You will have either a girl or a boy." Impressed by the old man's correct prediction, the foolish young man returns to him asking about a good name for the child. The story's outcome is a real groaner. **(Cubs: Reader's Badge 5)**

Picture books can also serve as effective, quick introductions to some Cub badges. Phoebe Gilman's *Something From Nothing* is a natural tie-in to the "reuse" section of the Recycling Badge. When Joseph was a baby, his grandfather made him a wonderful blue blanket, but, as Joseph got older, the blanket became worn and Joseph's mother said, "It is time to throw it out." Joseph disagreed, claiming, "Grandpa can fix it," and so he does, transforming it into a wonderful jacket. The cycle repeats itself several times until Joseph is left with just a button. As the book's illustrator, Gilman has added a separate wordless story involving a mouse family which dwells beneath the floor of Joseph's house. The mice also recycle by reusing Grandpa's discarded cloth scraps for their clothing and home furnishings. **(Cubs: Recycling Badge B)**

Sheldon Oberman's *The Always Prayer Shawl* also has a recycling component, but the story is better connected to the World Religions Badge. In early twentieth century Russia, Adam's Jewish parents decide to emigrate to

America; before Adam leaves, his grandfather (also an Adam) gives him his prayer shawl saying, "I am always an Adam and this is my always prayer shawl. That won't change." Readers and listeners follow Adam as he grows up, becomes a parent, and then a grandparent, replacing components of his prayer shawl as they wear out. Ultimately, Adam sits down with his grandson Adam at the synagogue and tells him how one day the Always Prayer Shawl will be his. Lewin's detailed paintings should lead to discussions about Jewish religious customs. **(Cubs: World Religions Badge 2)**

A personal face can be put on the Disability Awareness Badge via *How Smudge Came* by Nan Gregory. Only Ron Lightburn's soft, coloured pencil drawings inform readers that Cindy has Down's Syndrome. Finding a puppy, Cindy knows she won't be allowed to keep it at the group home where she lives; she smuggles the pup in nonetheless. During the day, Cindy takes the puppy to the hospice where she works. Eventually, the pup is discovered and sent to the SPCA. The story ends well. **(Cubs: Disability Awareness Badge 8)**

Book Details

Bourgeois, P., *Franklin Plays the Game*, Illustrated by B. Clark, Kids Can Press, 1995: \$4.95.

Davis, V., *Simply Ridiculous*, Illustrated by Russ Willms, Kids Can Press, 1995: \$14.95.

Gilman, P., *Something From Nothing*, Scholastic, 1992: \$5.99.

Gregory, N., *How Smudge Came*, Illustrated by R. Lightburn, Red Deer College Press, 1995: \$17.95.

Oberman, S., *The Always Prayer Shawl*, Illustrated by T. Lewin, Boyd Mills (available in Canada from McClelland & Stewart), 1994: \$19.99. X



38th Jamboree on the Air

An Eventful Experience

by Lena Wong

Twenty-one groups (totalling 1,035 participants) reported taking part in JOTA this year. They communicated with Scouting youth in 28 countries. For the first time, at least five Canadian groups participated via Internet (quickly dubbed JOTT). Of a total of 373 contacts, 217 were by Internet. These statistics are undoubtedly low as many groups never report their participation. Some Canadian groups incorporated their JOTA activities with camping; because of the early arrival of snow, some found it to be their first winter camping of the year.

A number of Canadian groups discussed UN50 projects with their contacts. 85th Lakeview Scouts in Calgary, AB, chose relief operations with an emphasis on preparing Scouts for emergencies. Their conclusion was that "Learning By Doing" was the best way to prepare for the unexpected.

Chilliwack District Scouts, BC, enjoyed broadcasting from a railway caboose. Meanwhile, on the eastern Canadian coast, New Brunswick Cubs and Scouts in Moncton talked to Scouting youth scattered all the way from Quebec to Greenland. They agreed that JOTA was "the best experience since the discovery of Nintendo and Sega Genesis."

St. Vincent's Scouts of Quebec joined members of la Fédération québécoise du guidisme et du scoutisme for an interesting and eventful experience. They

found themselves in a setting reminding them of an old French manor. In Embury, ON, the 1st Limoges Scouting Group had a great JOTA experience, though the Northern Lights interfered with their transmissions.

Porcupine District in Timmins, ON, used the World Jamboree's theme "The Future Is Now" as part of their activities. Their organizer Ralph Jenkins was an Offer of Service working with the radio station at the World Jamboree. His prized Canadian World Jamboree jacket disappeared on Saturday only to reappear at the top of the flag pole next morning!

In British Columbia the 21st South Surrey Troop hosted 500 participants throughout the weekend. They learned that in some countries UNICEF trains Scouts in health-related issues (e.g. hygiene, water treatment and nutrition). When they return home, they pass on this vital information to their communities.

1st Fort Saskatchewan in Alberta had a memorable contact with an airplane flying over Chicago, Illinois, while Oshawa District hosted 122 participants and recorded contacts with Disney World and the USS Requin Submarine #481 — a 1945 submarine from Pittsburgh, Pennsylvania.

In York Rouge District (Markham, ON) JOTA participants managed to connect to the automatic packet radio station aboard the Russian Space Station

MIR. The message received was, "Hello from Space Station MIR."

Scouts in the 1st Kilsyth Troop (Owen Sound, ON) met several interesting people on the airwaves. One person was a Utah youth called Denise who was trying to make as many contacts as possible. The 1st Kilsyth Scouts agreed that she was the fastest talking person they have ever heard on the radio! 1st McIntyre Scouts of Thunder Bay, ON, camped out at a lake on October 20. Not only did a tree fall on a nearby transformer, knocking out power for several hours, but 90 km/h winds and 8 cm of snow made JOTA camping a challenge. Despite it all, JOTA took place.

Many Canadians experienced difficulty because of very crowded airways; at other times ham operators wouldn't cooperate with JOTA participants. However, amateur radio operators helping to make JOTA a success were truly devoted to sharing their hobby and experiences with Scouting groups around the world. Our reports reflect a great deal of appreciation for these operators who made their facilities and equipment available to Scouting youth. [^]

Join in the fun. Start preparing for the 39th JOTA now. It takes place on October 19-20, 1996. Call or write for a copy of *Jamboree On The Air — How Canadians Can Participate* if you don't already have one.

A Well Dressed Pack Totem

by Brian Derick

Our pack didn't have a proper wolf's head totem until recently. Instead we used a wolf's head plaque on a short post which also bore the honour six of the month pennant. Our pack Scouters felt Cubs would really appreciate a more traditional totem, which might bolster their already strong interest in badges and build on *The Jungle Book* ambience.

We used a Scout Shop wolf's head which was realistically painted by the grandmother of one of our Cubs. (As a thank you, we awarded her the Artist Badge.) A local sugar bush provided staff-sized branches for the pole and log cabin style base. (The base doubles as an indoor campfire and Council Rock.)

B.-P.'s wonderful 1916 *Wolf Cub Handbook* shows a totem with Cub badges on it — a neat old idea. Noting the awesome challenge for Scouters and Cubs alike to become familiar with all the new pack badges and awards, we tried something a little different.

Dress It Up!

We started by purchasing a large size Cub sash and one of each award, strip, star and badge now available to Cubs. Three variations of the Religion in Life Award were added at the bottom of the back side. The badges were sewn on in the exact same order as they appear in *The Cub Book* — (Baloo did it while watching the World Series). Each award and the beginning of each badge section was marked with a bit of wool to help indicate which badges relate to specific awards and stars.

Scrap cloth, the same colour as the Cub uniform shirts, was sewn into the sides of the sash. Then we sewed on

Scout Shop crests of jungle characters and B.-P.'s famous tenderpad Wolf Cub drawing. A small hole in the top and bottom of the sash, a bit of velcro, and presto, our totem was sashed! We tied a turk's head on the pole above the sash, added coloured cords for each of our sixes, and another bit of velcro to hold the honour six of the month pennant. Grey plush fabric covers the base, representing Council Rock (easily removable to make a campfire), and a small overlay of fake tiger fur lies on the Rock to represent Shere Khan's hide.

But Do They Like It?

The Cubs think their totem is terrific. Not only is it colourful, but it's also a handy reference for badges and awards. Greasy fingers are not a problem — our Cubs consider it bad luck to actually touch the sash or badges. (A local legend says that if you actually touch a badge, it becomes more difficult to earn it. Hurray for legend-writers.) Pointing, on the other hand, is considered good luck. The sash is washable/dry-cleanable and is easily removed for bad weather or otherwise "challenging" outdoor use.

Dress your totem up! Give your pack a colourful focal point and guide to the Cub program. X

— Brian Derick works with the 27th Nepean "A" Pack, ON.



Photo: Bryon Milliere

You just can't beat a well dressed totem. It's inspiring!

When Beavers Lose Their Cool

by Ben Kruser

Sharing and cooperation.

These words epitomize the Beaver program. So, do Beavers ever fight? You bet they do! Rivalry between Beavers within a lodge or tail group is a normal occurrence. Perhaps one child feels another gets more attention, more craft material, or more chances in a game. Beavers can be inseparable friends most of the time and then, within minutes, face each other like spitting cats.

To help you keep peace between Beavers and maintain your own sanity, try these tips for handling youthful rivalry.

Jury's Out

Avoid becoming judge and jury right away. Help the children to calm down and work through their own problem by talking out their concerns. Use a simple problem solving method. Let the Beavers decide what their problem is, what alternatives exist, which is the best one, and how to implement an agreed-on solution. This method will help them greatly in the future.

The "Age"-Old Problem

Set realistic expectations. When working with mixed ages it's tempting to gear a program to either the youngest or oldest child. Don't expect Blue Tail Beavers to read lengthy instructions;

they might not be able to do it. White Tail Beavers should be able to fully act their seven year age. Don't expect more from them.

Communicate

Allow Beavers to share feelings openly. Give them permission to feel hostility toward other Beavers. Denying Beavers their feelings of anger only drives it underground. This can breed resentment and revenge. Let Beavers know it really can be difficult living with people who think or act differently than we do.

At times, real anger can make a child very frightened.

Share Your Feelings

Let your Scouting children know how similar your childhood experiences were to theirs; share your feelings with them. At times, real anger can make a child very frightened, so let Beavers know that you have sometimes been there too.

Forecast Emotional Hazards

If you're taking your colony on a field trip, think of situations that may cause problems. Long waits, eagerness to see one exhibit and not another, staying

with (or straying from) the group, not wanting to be someone's partner: if you come prepared to deal with these issues, you can diffuse them more easily.

Another potential disaster looms when leaders provide materials in assorted colours. A child who wants something green inevitably loses out because everyone else picks that colour first. To avoid disappointments, if possible, give children all the same items or choices.

Stay calm

It's easy to be sucked into the turmoil and tension if you stand between two fighting children. When youth get worked up over even the smallest issues, they find it difficult to regain composure and control. They look for an adult to help restore order so the Beavers can calmly sort out their problem. Getting involved in the fight and losing your temper tends to escalate a situation.

Be flexible

Plan "A" may work for a situation one day, and Plan "B" may prove more effective for the same situation another time. Work with Beavers to find out what they would do to resolve their concerns.

Sometimes leaders turn into referees on short notice. By setting the right tone, you've won half the battle. Sharing and cooperation: that's what it's all about. X

ONWARDS AND UPWARDS

During a combined Cub-Scout spring camp, youth from Alberta's 1st Edson Group decided to climb to the top of a nearby mountain. The conditions were perfect. Near the summit they paused just long enough to take this enthusiastic shot. Thanks to Robert Gliddon.



There's Gold in That There Trough! Cleaning up doesn't have to be dull work. Scouts from Victoria, BC, helped look after a gold trough and sluicing station operation during a local event that explained mining methods. At the end of the day part of the thrill involved finding the gold remaining in the gravel and dirt. René Dufleit generously provided the treasure. Photo: Courtesy of the Youth Service Corps, Victoria, BC.



No Homeless Birds In Our Neighbourhood Three Cub packs in Guelph, ON, are working together on a three year project that will see a total of 60 bird houses set up on the property of a local factory. Last fall the packs erected 19 houses along a nature trail bordering the property. Thanks to James Neville.



"Hi! I'm Alex." Cubs from the 1st St. Andrews Group, NB, had the pleasure of meeting Governor General and Chief Scout, Roméo Leblanc during an event last October in Market Square. Alex Haun, Ben Weaton, Alistair McDougall and Bryce Stuart shook hands with him shyly while Scouters Mike Power and Allie Lindsay cheered them on. Photo: T. Moffatt, St. Croix International Waterway Commission. X

It's a Wonderful Life!

by Rob Stewart

No, the title was not my idea. It was first used as the name of a video that Scouts Canada produced several years ago. We created the video to give new Scouters (and perhaps experienced leaders needing a refresher) help when planning outdoor activities.

The planning guide outlines five steps that will make almost any outdoor experience with your colony, pack, troop, company or crew a positive one. You'll find it useful regardless of the age of your group or the type of event you have planned.

This outline gives only a bare bones starting point for your planning. Your team will need to fill in all the dozens of details which go with organizing any event or activity; but don't be discouraged by what appears to be a daunting task. It gets easier every time you do it.

Step 1: Purpose of the Activity

- Have you and your fellow leaders defined the purpose of the activity?
- Is it planned around the section program goals?
- Will it be fun?
- Will it provide an opportunity to "learn by doing"?
- Will it test the skill of the youth, if applicable?
- Will it promote fellowship and cohesion in the group?

Step 2: The Site

- Have you identified a site?
- Is the site appropriate for the activity? Is it a safe one?
- Are there any potential hazards (e.g. traffic, fast-moving or deep water)?
- Is the site easily accessible for emergency vehicles?
- See the *Fieldbook for Canadian Scouting* for more information about site selection.

Step 3: Build the Program

- When you're brainstorming for ideas, don't forget to look in your hand-

- books, **the Leader** magazine and talk to other Scouters.
- Consider picking a theme based on the time of year, badge work or skill development. Your program planning leaders can choose from hundreds of interesting themes.
- Make sure youth play an active role when creating the program.
- Plan to teach necessary skills prior to the event (e.g. packing, menu selection).
- Ensure your program will not harm the site property.
- Seek permission if planning to use private land. Don't forget to "book" the campsite, if necessary.
- Consider the maturity level of your group; this will ensure activities are challenging, but not impossible.
- Review the timing of your plan.
- Create an emergency plan. Review the safety issues.

Step 4: Leadership

- Your leadership team must include a minimum of two responsible adults.
- Spread responsibilities around.
- Make sure the number of adults is appropriate for the number of youth.
- Decide who is responsible for checking the safety of activities, etc.
- Identify who will take over if an emergency occurs.

Step 5: Other Considerations

If your outside activity extends beyond an evening meeting night, make sure you consider the points below.

- Have you identified a drop off/pick up point for parents?
- Do you know of any allergies, special food requirements or religious concerns of your participants?
- Are there any participants who receive medications that they need monitored?
- Is your group committee and sponsor/partner aware of your plans?

Outdoor Resources

When planning fun, exciting and challenging outdoor activities, many resources are available to help speed the process. The booklet accompany-

ing the *It's A Wonderful Life* video lists many books under a variety of headings. These include astronomy, plants, amphibians and reptiles, insects, birds, mammals, environmental education, camping, canoeing and cooking. The *Fieldbook for Canadian Scouting* is also a comprehensive source for information and ideas.

Many councils across the country offer training courses designed to increase your outdoor skills, knowledge and comfort. Find out about courses in your area. Alberta's 21st Century program is an excellent example of a multi-level course designed to meet the needs of Scouters in all sections. For more information about it, call 403-283-4993.

The outdoors is a wonderful place to deliver our programs. It's the number one reason kids join the Movement. Get them out there. [^]



Paperweight Pots



by Ian Mitchell & Susan Albrecht

Every survival kit mentions a square of aluminum foil. It can be used to signal a rescue party, to reflect heat back from your fire, and as a cooking container. But how many of us would know how to make a cooking pot with the foil?

Sure, you can smooth it over a rock and make a pot that way. But what about actually creating a true pot?

If you want to offer a really challenging activity for your next spring campout, consider holding a "feeding frenzy from foil" event.

A what, you ask?

You could simply call it a tin foil cooking challenge, but it will involve much more than just wrapping food in foil and tossing it onto glowing coals.

Instead the event will consist of making tin foil cooking pots. Cap things off by constructing your own, custom-made drinking cups. Here's how.

Cooking Container #1

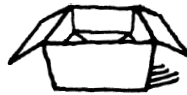

This pot comes complete with handles and is large enough to make a can of soup or a cup of tea. Make it with a piece of double thickness foil (30 cm x 30 cm).

Instructions

Start by cutting a square of foil, then follow these steps.

1. Fold the two opposite corners to the centre.
2. Fold each of the folded parts in half to the centre.

3. Fold in half (as indicated) ensuring that the folds face *outwards*.
4. Fold corners A and B (as shown) to make a crease. Insert forefingers and ease out only to the crease. Next fold over the crease to A, making a 90° side. Repeat for corner B. Your foil should now resemble a shovel.
5. Continue by flattening the shovel to resemble diagram #5. Turn over and repeat for the other side.
6. One side at a time, fold the three corners to the centre, diagram #7.
7. Repeat for the other side.
8. Diagram #8 shows what it should look like.
9. Fold in half, one side at a time.
10. Insert your forefingers in the opening indicated by the arrows, and gently open outward. Smooth the sides straight to give you your foil cooking container complete with two handles.

Cooking Container #2

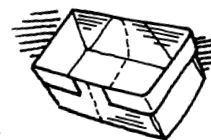

Once again, use a double thickness of foil (30 cm x 30 cm) or larger. Although this pot doesn't have handles it's still strong enough to boil two eggs or bake a cake.

Instructions

1. Fold each side into the centre (as shown).
2. Fold each end into the centre, and repeat again, to make 4 creased quarters on each side. Open flat after folding.
3. Fold each corner up to the middle, leaving about 2.5 cm along the edge unfolded.
4. Fold 2.5 cm along the centre on each side.
5. Using your forefingers gently open the folded container, smoothing out the sides and making the bottom square.

Container #3 (Drinking Cup)

This cup makes a favourite activity for a camping or hiking trip. It's simple for



19th World Jamboree

December 27, 1998 - January 6, 1999, Chile

The 19th World Jamboree will take place over the 1998/99 New Year during Chile's warm summer season. Thousands of Scouting youth from around the world will attend. Hosted by the Asociacion de Guias y Scouts de Chile, the jamboree's theme is "Building Peace Together."

Located near the town of San Francisco de Mostazal (about 60 kilometres south of the Chilean capital, Santiago), the jamboree site will be at a newly-acquired hacienda called "Picarquin." The area features many beautiful places for excursions, and offers a stunning view of the Andes, the coastal mountain range and the central valley.

The event is open to Scouting boys and girls aged 14 to 17 at the time of the jamboree.

Scouts Canada plans to assemble a contingent of several hundred participants who will be organized into composite troops of 36 youth and 4 leaders.

There will also be opportunities for young people between the ages of 18 to 28 to volunteer for International Service Staff positions helping the host country operate the event.

As well as the jamboree, the Canadian program will probably include pre-jamboree assembly and sightseeing. We're also hoping participants will be able to experience a few days of home hospitality.

young Scouts or even Cubs. Start with a square piece of foil (20 cm x 20 cm).

Instructions

1. Fold opposite corners of the foil together to make a triangle.
2. Fold corner A over until the tip touches the other side (A-1).
3. Turn the foil over and fold corner B the same way (B-1).
4. Tuck corner C into the fold.
5. Turn the foil over and repeat step 4.
6. Gently open the cup. When you're ready for a refreshing drink, simply

dip it into the nearest mountain stream.

Tin foil cooking requires patience and preparation. If you don't have a rack to put the pots on over the fire, make sure you have a good bed of hot coals. This means starting your fire prior to making your pots. Level out the coals before placing your pot directly on them. Another square of foil can act as a lid to keep the ashes out of your dinner. Tin foil heats up rapidly and can be quite flimsy, so remember to be careful and use pot holders.

Challenge your troop to see who can make the most elaborate meal using tin foil pots only. Go on an early spring hike and cook your lunch with the newly-made pots. Have a survival day. After you build your shelters, make supper using only tin foil pots. Be imaginative and have fun cooking!



Program Links

Scouts: Campcraft Badge (silver and gold), Cooking Badge
 Venturers: Outdoorsman Award

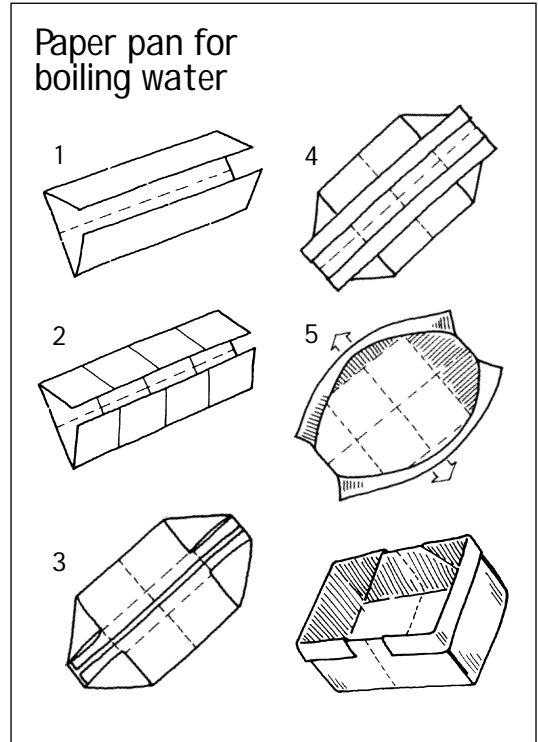
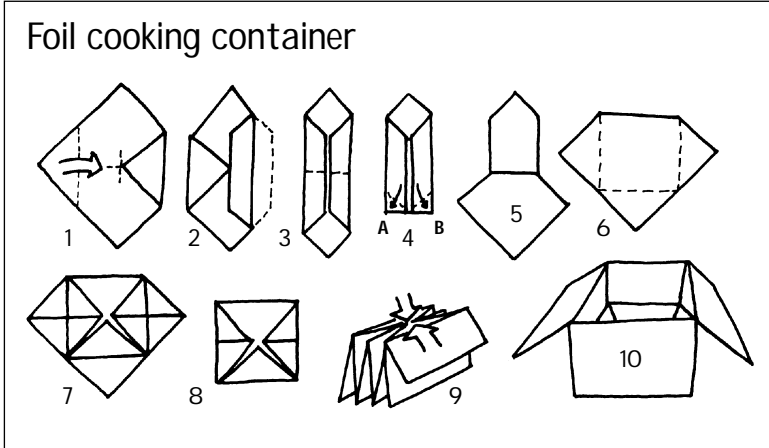
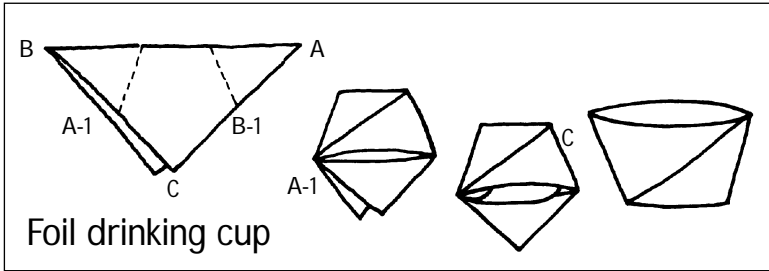

Service + Vocational = Challenge

by Ian Mitchell

Much like the greying of hair on a Venturer advisor's head, overlaps with in program activity areas are inevitable. When properly planned, overlapping will not only inject enthusiasm into learning, but also a sense of accomplishment. Here are two examples.

The "Medvent" Program

Medvents originated with a need for a large number of first aid and medical personnel for the 7th BC-Yukon Jamboree. Wanting to set up a team of trained first aid staff, Jeff Watts put together a group of 30-35 Venturers and Rovers, while building on experiences from CJ93. Eric Landymore, a Medvent and member of the 11th Richmond Bog-side Rovers, also contributed a great deal toward the program's success.

Their training began about a year before the event and included Standard First Aid and the First Responder Pro-

gram. Along with being expected to pass written as well as practical exams, the group was also trained in radio communications and received helicopter orientation.

To practise and improve their skills, the Medvents helped with medical services at various camps over the winter. Some youth had the opportunity to accompany experienced paramedics on the streets of Vancouver; while doing so, two performed CPR in real-life situations.

The hectic days of the Jamboree soon arrived. The week prior to the event was spent readying both the site and the equipment. Activities during the seven days included manning both the on-site hospital and off-site medical stations, radio dispatching, and mounting bike squads.

The Medvent program was a culmination of many hours of classroom and practical training (Vocational), resulting in a group of Venturers who attained a sense of pride and accomplishment through their contribution to the Jamboree (Service).

and how to set up emergency shelters for the homeless. The participants explored the area of stress debriefing and covered the day-to-day running of an emergency operations centre.

Participants in Greg's course probed into disasters of the past and built up their skills and knowledge by looking at case studies.

Have you ever thought about what happens to a flooded city? There's no electricity, sewer water lies everywhere, and the elderly are stranded. It's important to be prepared for emergencies which could happen at almost anytime in your community. Greg's Venturer company plans to use sections of the program he learned for their group emergency training.

Emergency training involves many of the vocational areas that youth want to explore in greater depth. At the same time it gives opportunities, such as emergency awareness and preparedness, that can help Venturers provide better service in the communities where they live. Contact your local Emergency Preparedness organization to find out more information.

Emergency Preparedness Training

Scouting has always strived to ensure that our youth are prepared for all circumstances they might encounter, so when Emergency Preparedness Canada invited a member to take part in their basic Emergency Preparedness "Safeguard" training program, we jumped at the chance. We wanted to explore ways how Venturers could become more involved in this area.

Greg McCormick, a Venturer and member of the Venturer Speakers Bureau, represented Scouting. Greg's background included being a member of an RCMP Venturer company as well as a member of the National Youth Committee (Forum).

"My main function," says Greg, "was to promote the use of Scouts, Venturers and Rovers in the emergency plans of representatives from communities around the country." He spoke frequently about Vocational Venturing to firefighters, police officers and search and rescue personnel. Over the seven days of training, the course touched on everything from allocation of resources and means of communication, to where

Challenging activities within the Vocational and Service program activity areas can sometimes be difficult to find. Try overlapping the two. The possibilities will become more interesting for youth, while at the same time give them a greater sense of contributing something worthwhile. ^

MOVING?

Please let us know. Print your new address in the space provided. Tape the address label that now appears on the cover of your LEADER in the box marked "Previous Address".

New Address

Name _____

Address _____

Prov. _____ Code _____

Previous Address

(Affix label here)

Mail to: **the Leader**
PO Box 5112,
Stn. LCD-Merivale
Ottawa, ON
K2C 3H4



VOCATIONAL VENTURER IDEAS

We're always looking for more vocational Venturing ideas. Share your thoughts with us. Send them to me, c/o Program Services, National Office, P.O. Box 5151, Stn LCD-Merivale, Ottawa, ON, K2C 3G7.

BADGE UPDATE: ENOUGH IS ENOUGH

by Ben Kruser

As the National Program Director for Cubs, I spent four years upgrading and promoting the revised Cub program. Except for the youth, no one was more frustrated than I to see their whole revised program (and the accompanying enthusiasm) nearly collapse because of badge shortages.

This constant irritant to leaders and youth has continued for too long. All of us involved in the supply chain share equal responsibility to make sure that badge shortages never occur. Supported by the National Supply Services Committee, we have taken the following corrective steps.

1. After completing a full evaluation of the badge inventorying systems used in Supply Services and local shops, on January 10, 1996 we issued a new policy to national purchasing staff. It stated: "Effective immediately, you are to ensure that badges never become back-ordered."

Purchasers can now buy up to a year's supply of any badge to overcome delivery-related problems, if necessary.

2. On January 24, 1996, our purchasing staff formally notified our major badge suppliers of the change in policy, thereby warning them in advance so that they would be ready to accommodate larger, less frequent, orders.

3. On February 9, 1996, a report was sent to all Scout Shop managers and executive staff detailing the reasons for the badge shortages, how this situation affects youth members and how to prevent the problem from reoccurring. Shop managers and their council executives were asked to review their own inventory practices to ensure that badges are kept well stocked at all times in their own stores. Shops across Canada and our warehouse will be working together to ensure all youth badges are always available when earned.

Badge Shortages Will End

In mid-February Supply Services started compiling purchase orders for our badge suppliers in preparation for this fall's sales. The total badge order (to meet current back-orders and fulfil bulk orders) is in excess of 600,000 units. In May, the purchasing staff and I will meet once again to review our badge inventory projections and place additional orders over the summer so that our warehouse stocks will be at full badge capacity by September.

There's only one thing worse than losing the trust of a leader; that's losing the trust of a youth member. The chronic problem of badge shortages will end now!

"Things are better well done than well said," to quote Winston Churchill. Our actions will only meet member approval if we live up to our intent. Please let me know if you experience any difficulty obtaining youth badges this fall.

On behalf of all those involved, please extend our sincere apologies to your youth members for the frustration and inconvenience caused by this problem. X

Double the Beavers, Double the Fun

by Els Cawthorn

In Prince Edward Island, Woodbadge Part 2 courses are carried out over a period of three separate weekends. This gives leaders time to try out new ideas and then gather back together with the results. It also lets instructors assign 'long-term' assignments. Here's a project that our group found particularly inspiring.

The combined noise of fifty happy Beavers bounced around the church hall. The walls were shaking, the floor was vibrating, and for several minutes older Scouters thought the roof might come off. There were drums, tambourines, guitars, shakers, flutes and cymbals all making music (noise?) with wild abandon. This was a Woodbadge 2 experiment, and boy, was it working!

It all started in January 1994. At the first weekend of our Woodbadge 2 training the instructors asked us to get together with another Beaver colony in our area to organize a joint meeting. The purpose of the exercise was to expose new leaders to planning sessions, to discuss the merits of various ideas, and to give the leaders and Beavers of the in-

dividual colonies a sense of sharing. Plans for the evening were to be submitted at the next Woodbadge weekend in March, and the joint meeting was to be held in April or May. In our area, leaders of the 1st Cornwall Beavers and the West Royalty Beavers arranged not one, but two Beaver exchanges.

The first meeting was held in West Royalty. Beavers listened spellbound to Maurice Roy, an officer from Parks Canada. He discussed the effect winter has on animals in the National Park, why snowshoe hares change colour, why some animals hibernate, and how animals find food and shelter. He illustrated his talk with beautiful slides and entertaining stories. Mr. Roy explained that the stuffed hare, grouse and beaver he brought had been found dead, and had not been killed for display. Some Beavers played the role of snowshoe hares in the snow outside while others imagined themselves to be red foxes. Officer Roy answered many of our Beavers' inquisitive questions about animals and nature.

The Cornwall Beavers hosted the second meeting — a celebration of music that set the church hall echoing with youthful enthusiasm. Leaders divided the children into small groups; each made one kind of instrument, one per Beaver. Old Kleenex boxes were converted to guitars, empty baby food containers made beautiful shakers, sturdy paper plates with little bells attached served as tambourines. Beavers also made drums, flutes and cymbals. Then everybody participated in an exuberant march through the church, after which we shared a sing-along. Both colonies had prepared for this event by practising some of their favourite songs. What an incredibly good time we experienced.

At both meetings, we shared an opening and closing ceremony, and a Scouter's Five. The children were thrilled to have so many Beavers together for their tail slap. When our dam filled the room completely it gave them a real sense that Scouting's boundaries go beyond our own colonies. The Scouter's Five after the music night focused on sounds and silence. Silence after so much loud excitement, you say?! Impossible? We had fifty excited Beavers as quiet as mice trying to hear peas roll over the floor. There's always a creative way to accomplish the impossible.

All the leaders enjoyed the experience of combining the colonies for these two nights. We had fun evenings that gave us and the children some great memories. We also got to know each other a bit better, learned to share ideas, and found out that a Beaver music night does not produce permanent deafness.

Our Woodbadge 2 assignment achieved its goals. It gave leaders a better perspective on planning, it gave Beavers a sense that we all belong to a larger organization than our own individual groups, and it gave Scouters a feeling of joy and satisfaction to see so many happy young faces.

Share some of your meetings with another colony. It might be part of a Woodbadge assignment or it might be aimed at just having a good time. Expect unforgettably good memories. ^

— Els Cawthorn ("Rainbow") is a busy leader with the 1st Cornwall Beaver Colony, PEI.

SCOUTER'S 5

A Personal Creed

- Native people have developed a personal creed that builds integrity while also giving focus to life. It allows them to view life as a constant healing and regeneration process because it avoids negative rules.
- Get your Cubs, Scouts and Venturers to make up their own personal creeds, writing them out on thin cardboard. Laminate with mactac (clear, adhesive plastic) so they can carry the cards wherever they go.
- Here's an example of a personal creed to start them off.

To the best of my ability...

I intend to respect all life,
I choose to be accountable for my decisions,
I intend to support elders and children with
my time, my resources, and my caring,
I choose not to judge myself or others harshly,
I choose to speak the truth in all situations,
I choose to learn from my mistakes and
shortcomings,

- I choose not to revile or abuse myself with undue criticism or to reject my human growth process.

— *From Guy Mandeville, Kingston, ON.*

Quotable Quotes

To act justly between two people is a charity; to help a man with his mount, lifting him onto it or hoisting up his belongings onto it is a charity; a good word is a charity; every step removing a harmful thing from the road is a charity.

— *Hadith (Traditions)*

Scouter's 5 Minutes, p.759

April '96

SONGS

The Trainer's Theme Song

(Tune: "Wild Rover")

- When your Woodbadge participants need some encouragement, get out the guitar and sing this comical song.

○ G C
B.-P. decided that training was due
G D G
For leaders who wanted to know what to do

○ C
It started in Gilwell with beads for reward
G D G
And spread the world over blessed by the board.

Chorus:

G D
And it's no nay never
G C
No nay never no more.

G C
Will we have untrained leaders?

○ G D G
No never no more.

It starts with a Gateway the basics are here,
Then on to a Woodbadge Part 1 in a year.
Then if you can see that improvement is due,
You take further training it's called Woodbadge 2.

○

Chorus

Now if you develop a need for the skills
There are courses in first aid to cure all your ills.
And camping and outdoors, boat rescues and
morse,
Then advance to a trainer teaching others the
course.

○

Songs, p.107

April '96

Be a

leader

Reader!

Leading the way
10 times a year!

Mail to: Box 5112, Stn LCD-Merivale
Ottawa, ON K2C 3H4

Subscription
rates:

Registered Adult Members Scouts Canada \$7.49 / year (Includes GST)
Others in Canada \$10.70 / year (Includes GST)
Outside Canada \$18 / year

Please send me the Leader. I enclose my cheque (money order) for:

1 year 2 years new subscription advanced renewal

Please charge my: Visa Mastercard Card no. _____

Expiry Date: _____ Signature _____

Name _____

Address _____

City _____ Prov. _____

Postal Code _____

the **leader**

G.S.T. Reg. No. R100 794528

Chorus

Now heed what I tell you prepare for the day,
That you put into practice at work and at play.
The lessons and knowledge impart to you,
The youth will enjoy it and then so will you.

— *By Terry Dyche, Ottawa, ON.*

My Napkin on My Lap

(Tune: "My Knapsack on My Back")

Feel like taking on a real challenge? You might try to reinforce table manners. Here's a fun song to set the mood.

I like to go to restaurants
With my mom and dad
I mind my manners and I place
My napkin on my lap.

Chorus:

Etiquette, etiquette, etiquette, etiquette...
Etiquette, etiquette,
My napkin on my lap.

I don't eat with my fingers
And I don't slurp my soup
My elbows off the table and
My mouth closed when I chew.

Chorus

I don't reach for the butter and
I say please pass the broth
I don't pig out on pickles and
Wipe my hands on the table cloth.

— *Glen Foster, Nanaimo, BC.*

Songs, p.108

Whosoever of you sees an evil action, let him change it with his hand; and if he is not able to do so, then with his tongue; and if he is not able to do so, then with his heart.

— *Hadith (Traditions)*

With the coming of spring,
There is blossom on every spray.
In the same fashion,
With the coming of inner devotion to God,
All sentient creatures have an inner blossoming,
And in this way the mind becomes fresh and green.

— *Rag Basant*

May I never hurt or harm any living being. May I never speak a lie. May I never be greedy of wealth. May I ever drink the nectar of contentment.

Be With Me Today

Grant me the strength to do the tasks that every hour demands. Give me hope and faith, a happy heart and willing hands. Be close to me O Lord and hear me when I call. Light a star above my path when twilight shadows fall. Help me to accept whatever comes with every day. And if I meet difficulties and troubles, please lead me by quiet, peaceful waters where my soul can find friendship and peace with you.

— *By Patience Strong. Thanks to Virginia Dorais.*

Scouter's 5 Minutes, p.760



A Chance to Celebrate Youth

by Steve Kent

“You’re in Scouts?” some of your acquaintances say. “You mean you sell apples and help old ladies across the street? Scouts are geeks!”

If only these people knew about the great things we do. If only they knew about the fun, the challenging activities, and the friends we make. It’s time to let them know!

Scouting is a great Movement of young people and for young people. Recently Scouts Canada has realized the need for a stronger youth voice and for greater youth participation in planning and decision-making. Our young members have become more informed and actively involved at all levels. We’re headed in the right direction.

Want a taste of International Scouting?

Register now for the

Toronto Friendship Camporee '96!!

Meet Scout groups from Japan, USA, Bangladesh and Hong Kong. Visit the falls, Fort George, Marine-land, and the Scout Museum.

Where: Niagara Falls
Date: August 1-2, 1996
Cost: \$10 per person

Send registrations *before* **April 30, 1996** to:

The 16th Toronto Sea Scout Troop
c/o C.I.C.S.
3852 Finch Avenue East
Suite 310
Scarborough, ON
M1T 3T9

Youth Week

More needs to be done to convey positive images of Scouting to young people who are not currently enjoying its many programs. Youth Week '96 is an excellent opportunity to motivate and inspire young people to get involved. Youth Week (April 29 — May 5, 1996) is also a great time to highlight the achievements of our members and to raise awareness of the valuable contribution that Scouting groups make to their communities. Why not get your group involved?

Youth Week is one of the many projects of the Youth Action Network. This Network is a fully independent, non-profit organization committed to the betterment of our world. Like Scouts Canada, the Youth Action Network believes that young people are an important source of untapped potential in communities across Canada. Youth Week will serve to raise the level of youth participation to unprecedented heights.

How can you play a role?

The possibilities are endless! It's easy to find an activity meeting your group's interests that ties in with Youth Week. Here are a few ideas.

Linking, Service, Conservation

One of the goals of Youth Week is to create links among youth organizations. What a great time to link the sections in your group. For example, Cubs and Scouts in your group could plan a joint meeting or outdoor activity.

Service projects are an excellent way to raise awareness of your group's community involvement. Let youth members select a special service activity that interests them. It may entail holding a food drive, volunteering at a hospital or senior citizen's home, or assisting with an event for a younger section. Recent statistics indicate that only 20% of Canada's youth between the ages of 15 and 24 volunteer on a regular basis. Imagine how much stronger Canada could be if twice as many young people were more actively involved.

Scouts Canada has advocated for a long time that good conservation is good citizenship. An environmental initiative would also be appropriate during Youth Week. Arrange an environmental

awareness presentation for your group, or hold a clean-up of a local park, river or neighbourhood.

Money certainly isn't everything, but what group can survive without it? Youth Week may be an ideal time to conduct a fundraising activity.

The Week would also be a good reason to hold a district or regional event. There's power in numbers! If you do hold a large event, consider incorporating some kind of rally or celebration.

Hold a leadership training event for your youth. Arrange a special presentation or workshop on an issue that interests or concerns group members.

Put up posters or air public service announcements to inform others about your group's activities. Assisted by your district or regional service team, organize a presentation at a school. I recently was talking to an adult volunteer who designed a presentation, contacted a local school, gave the presentation, recruited close to twenty new Scouts and leaders, and then helped his recruits start a new troop. He made it look so easy! Once young people realize what wonderful things Scouting can offer them, many will want to join.

Youth groups and organizations are conducting forums, rallies and conferences to celebrate Youth Week. What a great time for a Scouting youth forum.

What ideas do you have? No matter what you decide to do, be sure to seek support from local media. Prepare a news report on a special group activity. Attempt to get television coverage of a Scouting event. Send out news releases to inform the media of your plans. The media can help improve Scouting's image and recruit new members.

It's important to recognize youth achievements and encourage young members to make contributions to their communities year-round. Do your part. Get involved with Youth Week '96. The ideas and work of young people are definitely worth celebrating!

For more information, please contact me directly at 1-709-368-1639, or call Uma Sarkar, Youth Week Coordinator, at 1-800-718-LINK. \

— Steve Kent chairs the National Youth Committee.

SCOUTS CANADA'S WORLD WIDE WEB SITE

by Phil Chant

It struck me like a brick. It was early Sunday evening, February 11, and I had just finished fine-tuning the pages for Scouts Canada's new official World Wide Web (WWW) site. Tomorrow morning I would give the final computer instructions to open our site to the Internet community in Canada and around the world. This is *instantaneous publishing* to thousands who have, or might have, an interest in Canadian Scouting.

Finished that, I'd sit again at the computer, but this time to write the article you're reading now — text frozen on paper in mid-February, but not readable until April when **the Leader** hits the mailboxes of Scouters across Canada. I wrote it in February, but you're only reading it now, almost two months later.

Instant Publishing

No wonder the world is excited about Web publishing. The marvels of the World Wide Web and the Internet involve *instant* communication and opportunities for exponential growth.

In 1983, 562 computers were on the Internet. By 1989 that number had jumped to 80,000. Over the last two years major on-line services (e.g CompuServe) have moved aggressively into Canada with wide public access to the net. Six months ago, *Time* magazine reported:

- 37 million people (17% of the US and Canadian population 16 years and older) have access to the Internet.
- 24 million used the Internet in the past three months
- people spend an average of 5 hours, 28 minutes on the Internet per week
- 66 % are male, 34 % are female.

These are just North American numbers. Worldwide the Internet transcends international boundaries.

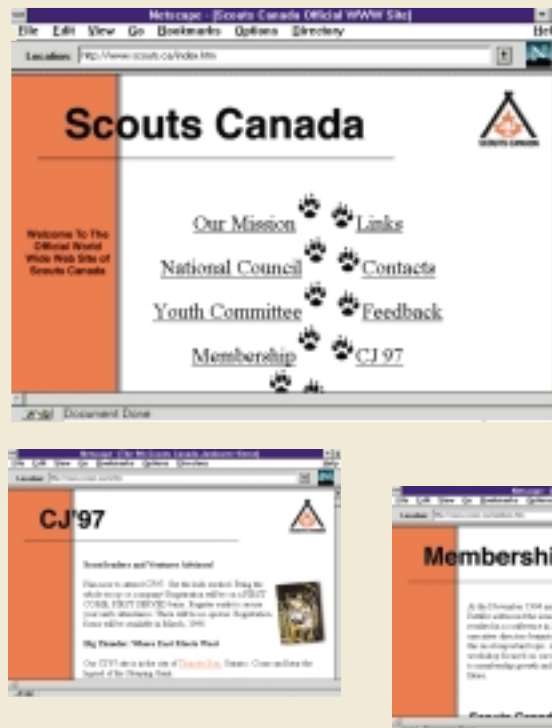

← If you have access to the internet, sights like these await you.

A Giant Youth Magnet

The Internet attracts youth by the very nature of its computer base. Nearly half of our own Youth Committee members have e-mail addresses, indicative of the interest within our membership. Cub packs and Scout troops in Canada are establishing their own World Wide Web sites.

Scouts Canada presence on the World Wide Web is not solely aimed at the Canadian Scouting fraternity. Clearly a much wider potential audience exists for our information, both from the general public and people in other countries. The content must be both specific and general: specific enough to provide detailed information on CJ97, yet general enough to answer a parent's questions about the value of Scouting.

Our site (<http://www.scouts.ca>) took three months to design, but a web site is never finished. New subjects and new information are always in demand by visitors. The construction process makes this new communication channel an exciting one. At its inaugural, the Scouts Canada pages had content on our Mission, our five youth programs and The Boy Scouts of Canada Trust.

It contained a directory of addresses and telephone numbers for our provincial offices, and active links to other Scouting WWW sites around the world. One of the first congratulatory messages received after our start-up was from the Scout Association of Australia.

Where to next? Given our interest in youth, it's only natural that our site should contain specific items and areas of interest to them. When I wrote this article, our pages invited visitors to author these pages on our site.

The official Scouts Canada World Wide Web site was coordinated by the Communications Committee of National Council. The computer server site is donated by Robert ("Hawkeye") Noseworthy, president of WorldLink Internet Services in Ottawa. Page design and HTML coding was donated by David Chant of Toronto, (a former Beaver, Cub and Scout) who is a "new media" consultant with several WWW designs to his credit.

Now that you know about our site, try it out. ^

— Phil Chant is the Chair of Scouts Canada's Communications Committee.